



LEON CUP RACER



2015

WORKSHOP MANUAL

INDEX

1	TURBOCHARGER.....	3
1.1	Turbocharger, exploded view	3
1.2	Turbo compressor: removing and fitting	9
2	IGNITION SYSTEM.....	18
2.1	Ignition system: Assembly overview	18
2.2	Ignition coils with output stage: removing and fitting.....	20
3	OIL SUMP.....	22
3.1	Assembly overview - sump, oil pump	22
3.2	Removing and installing oil level/oil temperature sender -G266-.....	28
3.3	Remove and install the lower element of the oil tray	29
3.4	Remove and install the upper element of the oil tray	33
4	INTAKE MANIFOLD WITH THROTTLE.....	39
4.1	Intake manifold: Assembly overview	39
4.2	Exploded view - fuel rail, direct injection.....	41
4.3	Exploded view - fuel rail, intake manifold injection.....	44
4.4	Intake manifold: Removing and installing.....	46
4.5	Removing and installing throttle valve module -GX3-	53
5	ALTERNATOR	56
5.1	Alternator without sliding bushes -exploded view-	56
5.2	Removing and installing the alternator, vehicles with 1.8 litre TSI engine.....	57
5.3	Tightening torques: Alternator:	61
6	DIFFERENTIAL.....	62
6.1	Assembly overview – Front differential lock.....	62
6.2	Removing front differential lock	63
6.3	Installing front differential lock.....	67

1 TURBOCHARGER

1.1 Turbocharger, exploded view

Part I

Part II → [Anchor](#)

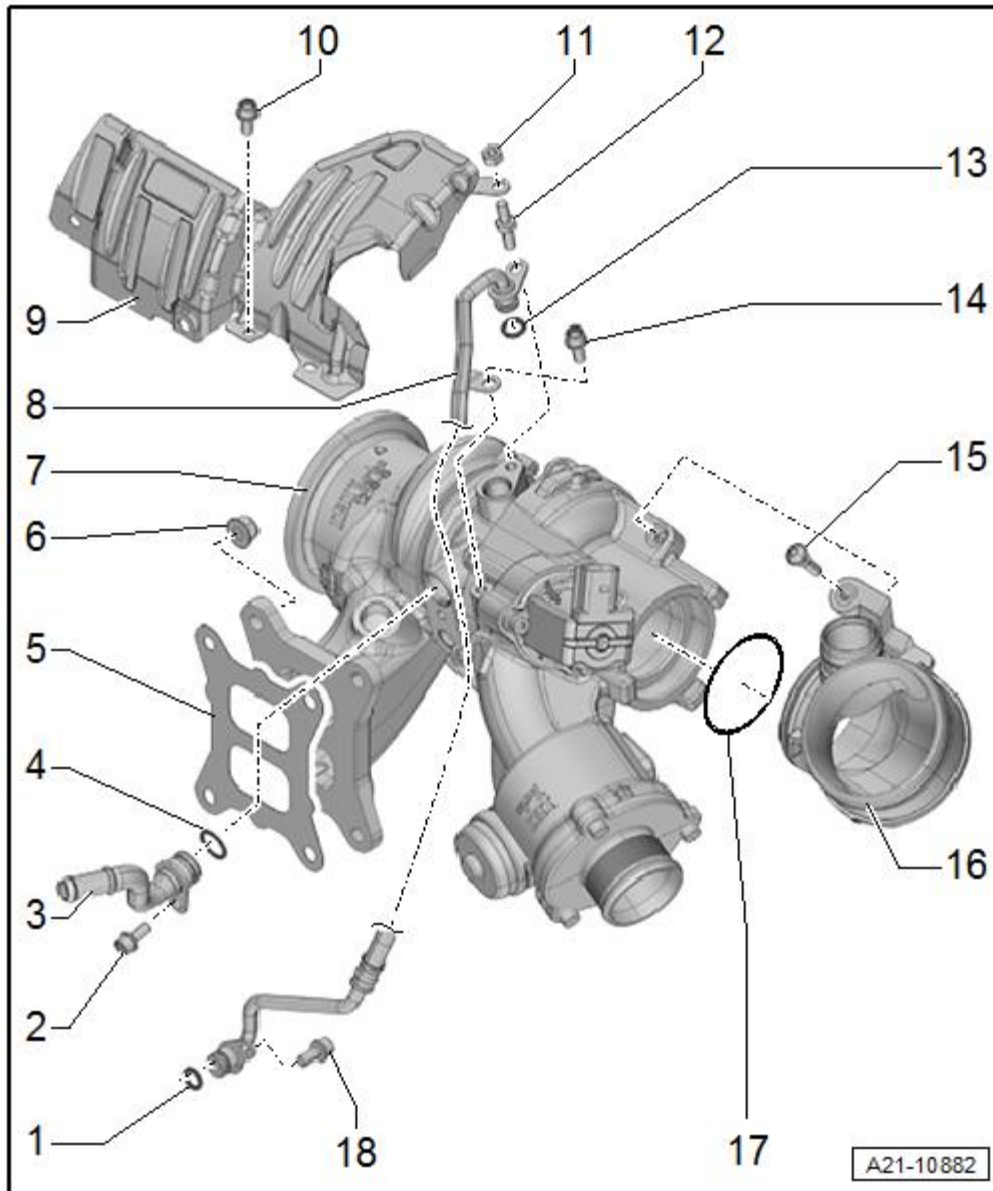

1 - O-ring

- Renew
- Lubricate lightly with engine oil

2 - Bolt

- 9 Nm.

3 - Coolant supply line

4 - O-ring

- Renew
- Lubricate with coolant

5 - Seal

- Renew

6 - Nut

- Renew
- 25 Nm.

7 - Turbocharger

- remove and install → [Chapter](#)

8 - Oil supply line

9 - Heat shield

10 - Bolt

- 9 Nm.

11 - Nut

- 9 Nm.

12 - Bolt

- 9 Nm.

13 - O-ring

- Renew
- Lubricate lightly with engine oil

14 - Bolt



WORKSHOP MANUAL LEON CUP RACER

□ 9 Nm.

15 - Bolt

□ 9 Nm.

16 - Coupling

17 - O-ring

□ replace

18 - Bolt

□ 9 Nm.

Part II

Part I → [Anchor](#)

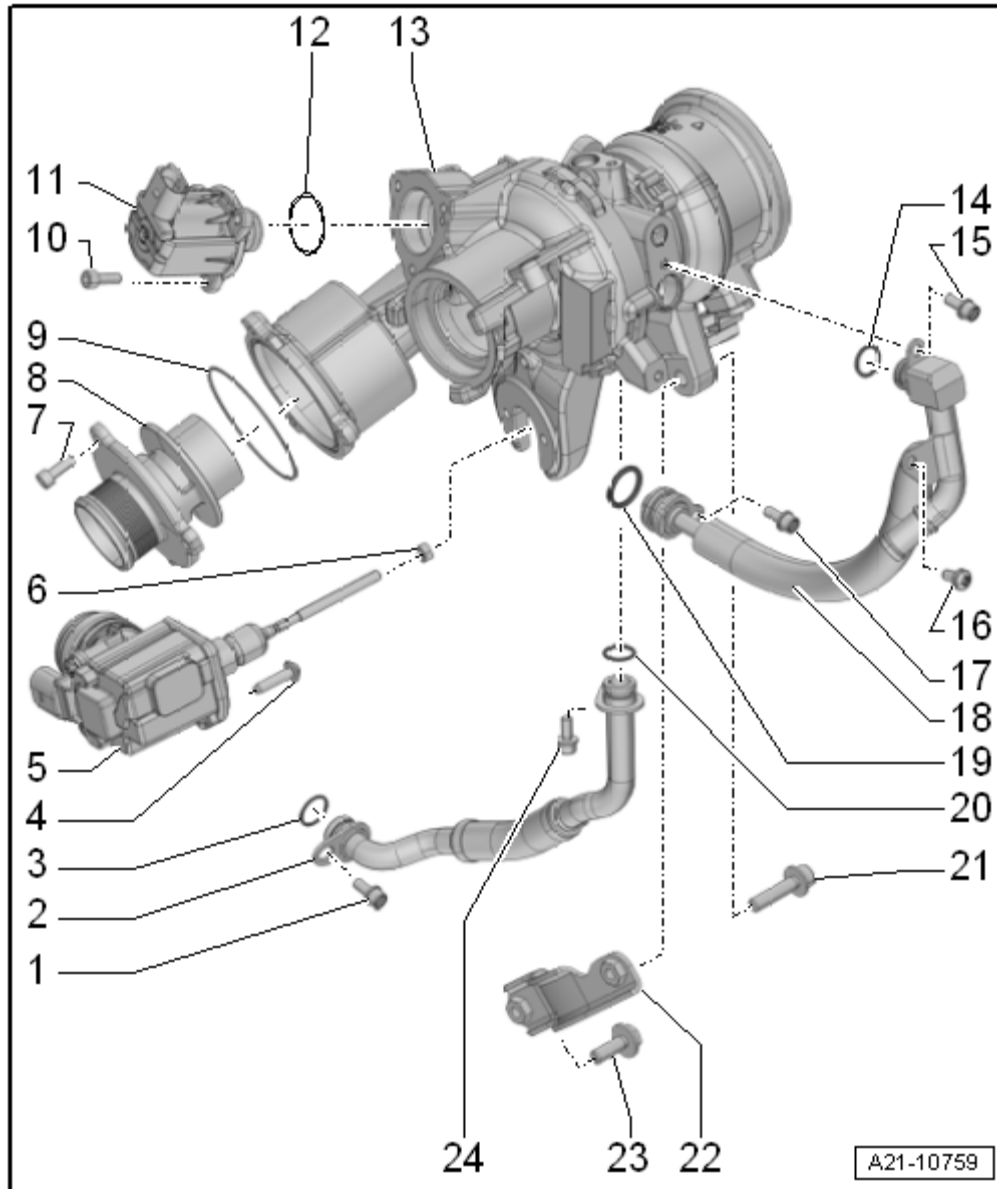

1 - Bolt

- 9 Nm.

2 - Oil return line

3 - O-ring

- Renew

- Lubricate lightly with engine oil
- 4 - Bolt
- 9 Nm.
- 5 - Charge pressure positioner -V465-
- 6 - Nut
- If nut has been loosened, charge pressure positioner -V465- must be renewed
 - 10 Nm.
- 7 - Bolt
- 10 Nm.
- 8 - Coupling
- 9 - O-ring
- replace
- 10 - Bolt
- 7 Nm.
- 11 - Turbocharger air recirculation valve -N249-
- Note installation position → [Fig.](#)
- 12 - O-ring
- Renew
- 13 - Turbocharger
- remove and install → [Chapter](#)
- 14 - O-ring
- Renew
 - Lubricate with coolant
- 15 - Bolt
- 9 Nm.

16 - Bolt

- 9 Nm.

17 - Bolt

- 9 Nm.

18 - Coolant return line

19 - O-ring

- Renew
- Lubricate with coolant

20 - O-ring

- Renew
- Lubricate lightly with engine oil

21 - Bolt

- Coat thread with high-temperature paste; for high-temperature paste refer to
→ Electronic parts catalogue
- 30 Nm.

22 - Support

- For turbocharger

23 - Bolt

- 30 Nm.

24 - Bolt

- 9 Nm.

Fitting location of turbocharger
air recirculation valve -N249-

– Note installation position -
arrows-

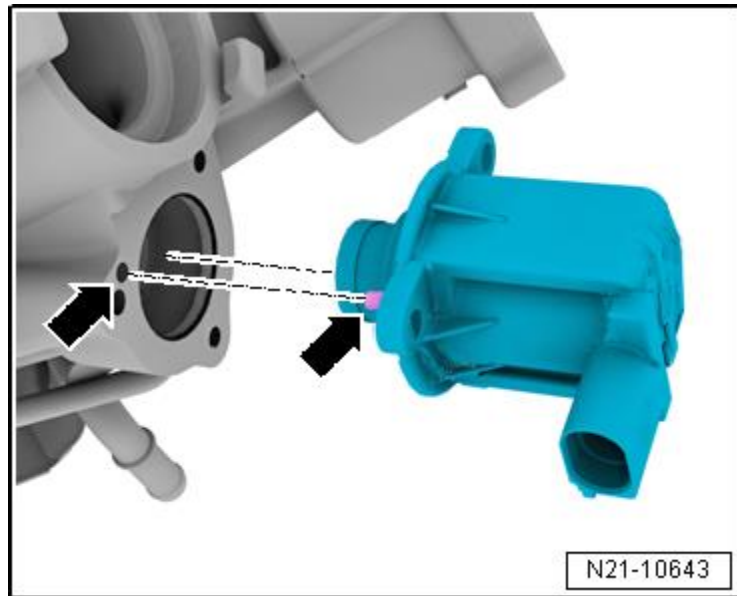

1.2 Turbo compressor: removing and fitting



Caution

If a mechanical fault is discovered on the turbocharger (e.g. a destroyed compressor impeller), it is not sufficient to just renew the turbocharger. To avoid any subsequent damage, the following work must be carried out:

- ◆ Check air cleaner housing, air filter element and air hoses for dirt and foreign particles.
- ◆ Check the whole charge air path and charge air cooler for foreign objects.
- ◆ If foreign matter is found in the charge air system, clean all relevant ducts and hoses and renew charge air cooler if necessary.

Special tools and workshop equipment required

- ◆ Engine bung set -VAS 6122-

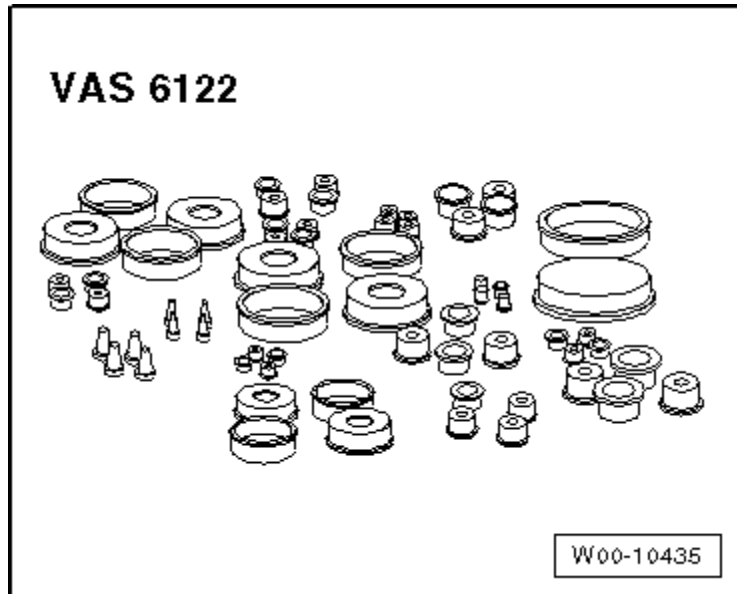

- ◆ Hose clip pliers -VAS 6362-

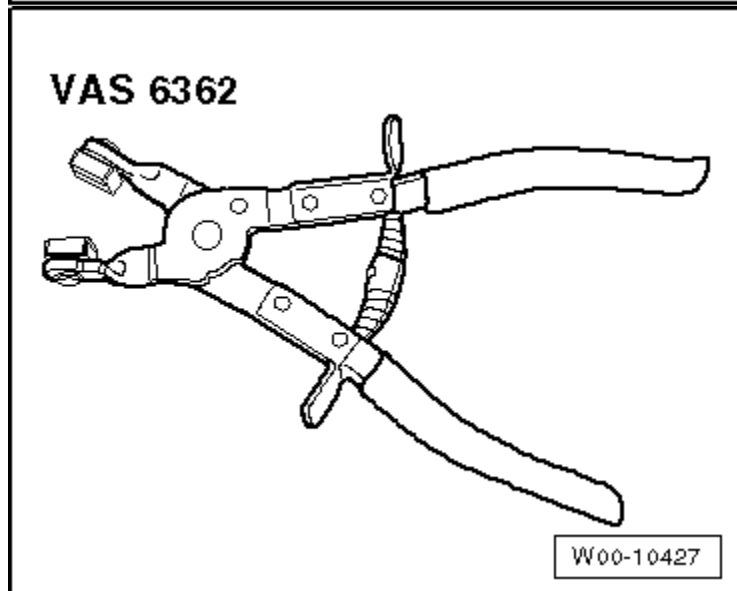

- ◆ Support tool -T10038-
Removing



Caution

Risk of malfunctions caused by dirt.

Observe → Chapter „Cleaning rules“.

- Drain coolant → Chapter.
- Removing front exhaust pipe with catalytic converter → Chapter
- Remove the air filter housing → Chapter.
- Remove Lambda probe - G39- → Chapter „Lambda probe - overview“.

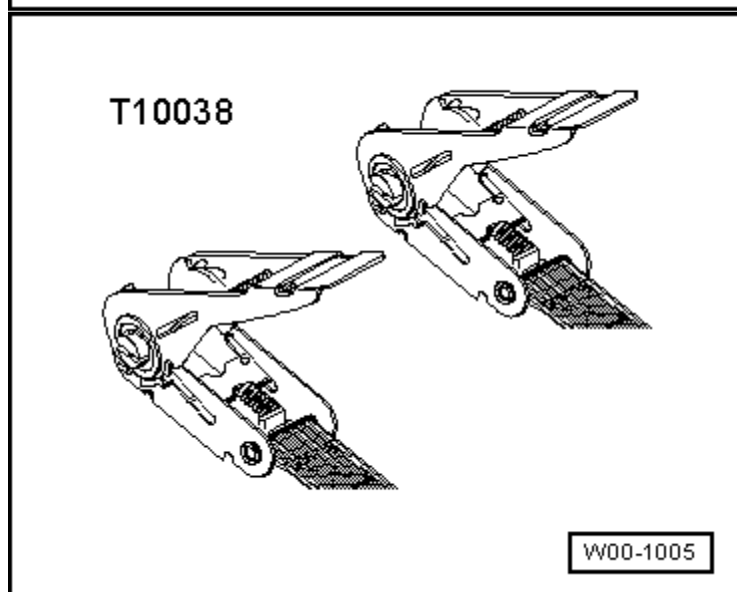

- Release the hose clamp - 2-.
- Remove bolt -1- and press air pipe (left-side) towards left slightly.

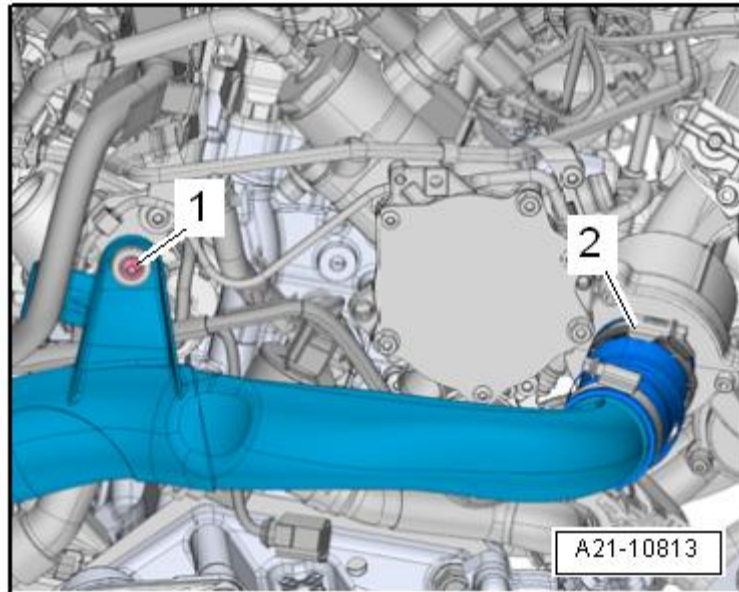

- Remove coolant hose - arrow-.
- Separate connectors -1- and -2-. Open retainer -3-.

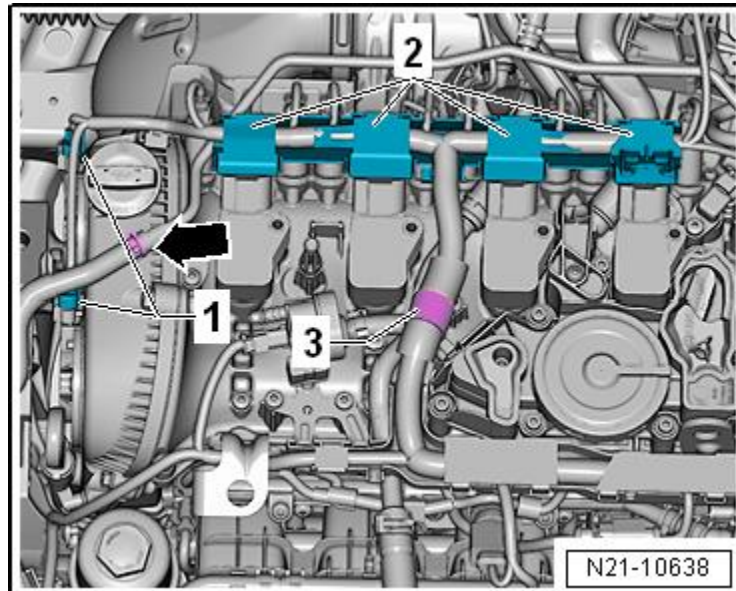

- Remove bolt -1- for earth cable and remove coolant hose -2-.
- Pull off connector -arrows-.

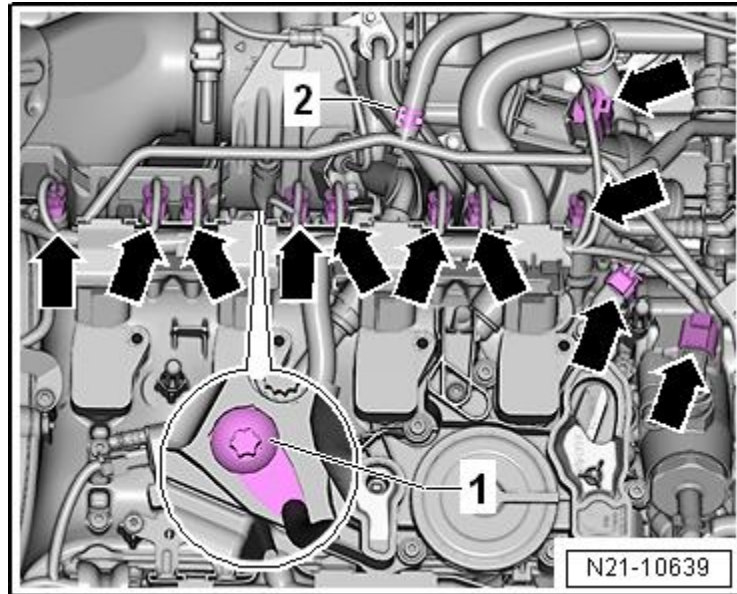

- Release fastener -arrow- and remove wiring duct -4- upwards from bracket.
- Unscrew the bolts -1, 2 and 3-. Swivel coolant pipe to the side.
- Remove Lambda probe 1 before catalytic converter -GX10- → [Chapter](#).

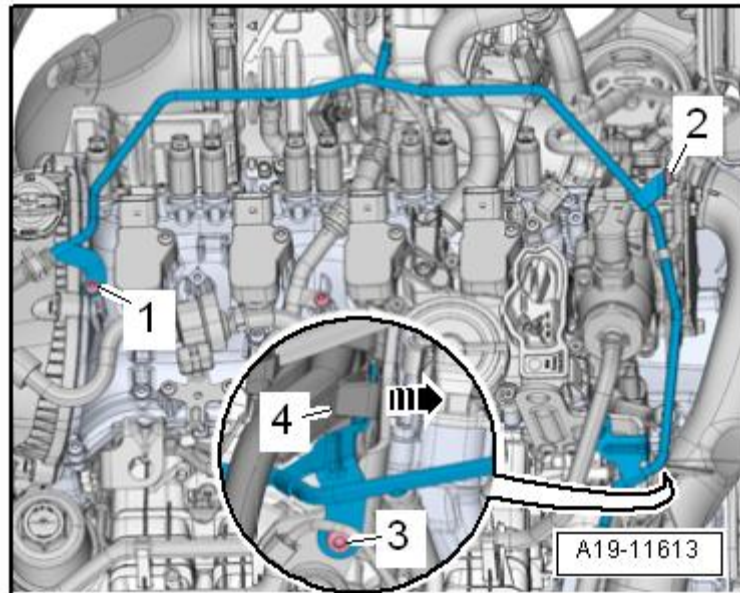

- Remove actuators for camshaft adjustment - arrows-
- Removing ignition coils with output stages → Chapter

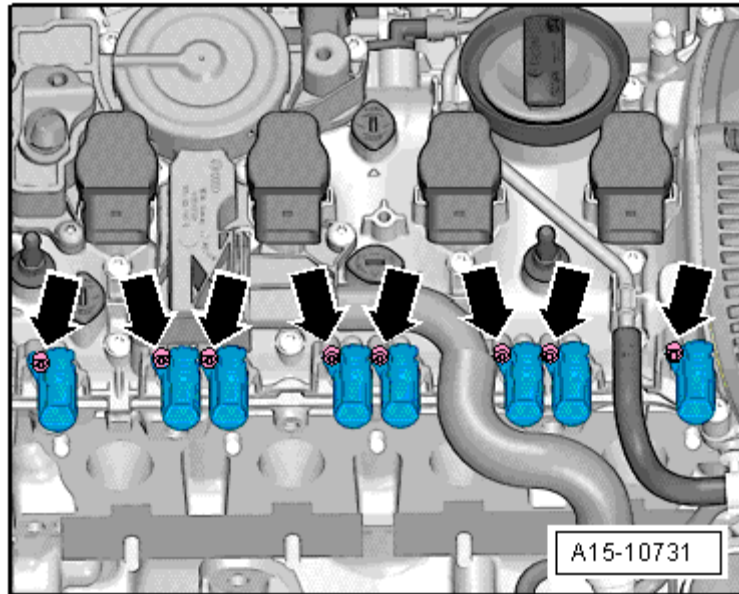

- Remove bolts -arrows- and nut -1-.
- Detach heat shield -2-.

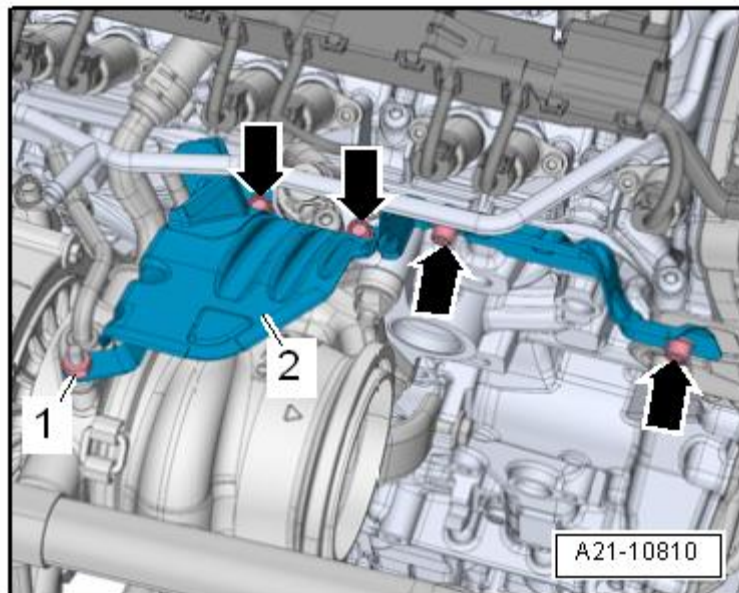

- Remove bolt -1- and loosen bolt -3-.
- Remove bracket -2- for turbocharger.

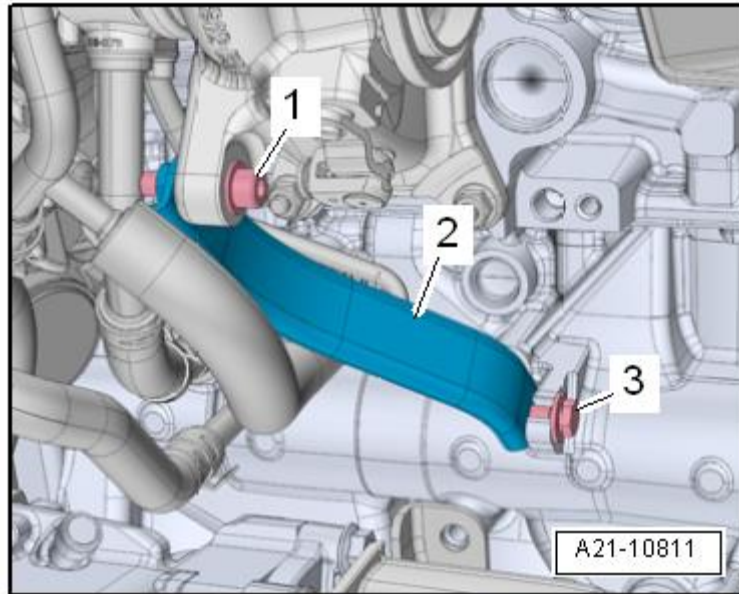

- Detach electrical connectors -1, 3-.
- Press release tabs on crankcase breather hose -2- and detach hose.

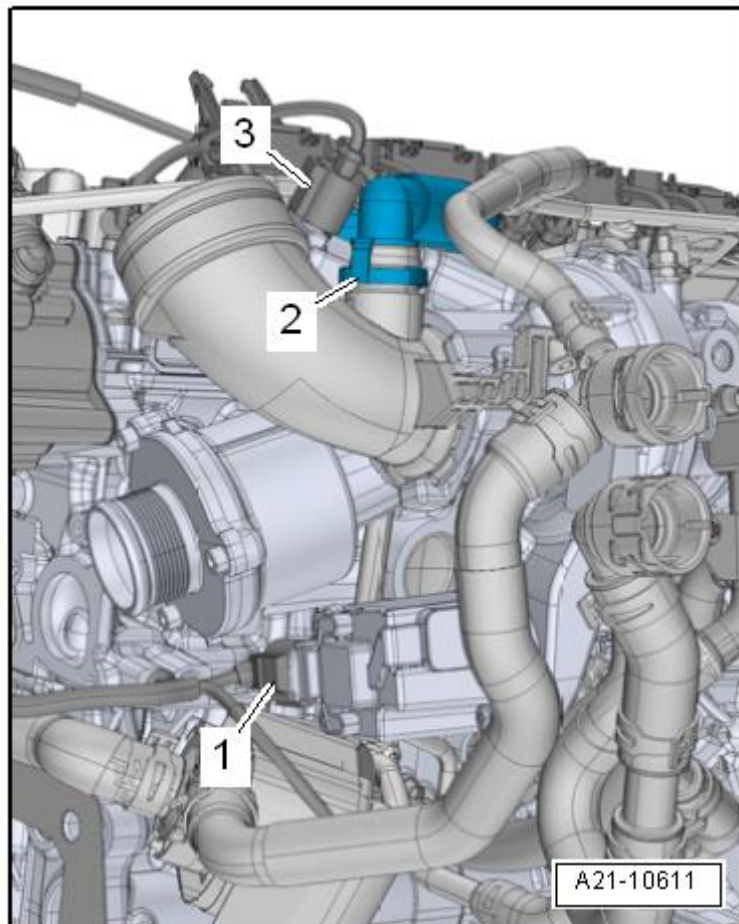

- Remove bolts -1- and detach connection.
- Unscrew bolts -2, 3- and detach oil supply line and oil return line.
- Release hose clip -arrow-.



Note

The following procedure is necessary to provide more space between the cylinder head and bulkhead.

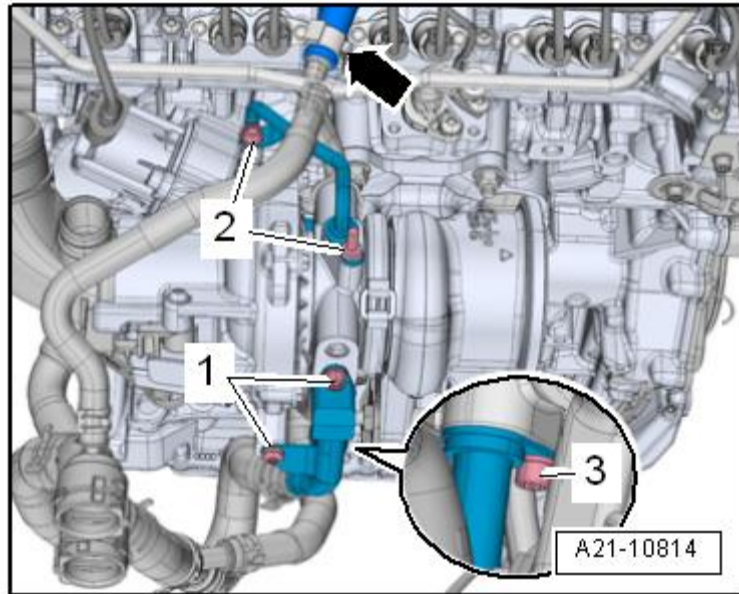

- Unscrew bolts -1, 2, 3- and remove pendulum support.

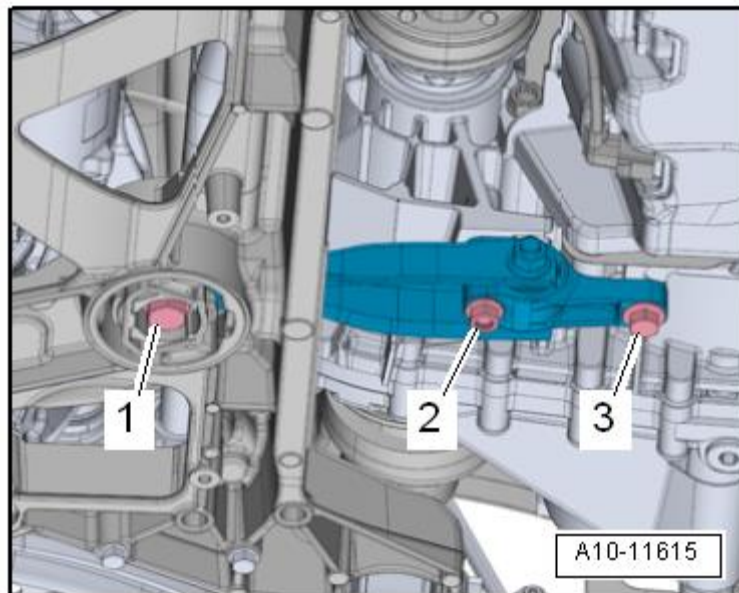

- Pull engine back approx. 20 mm with tensioning strap - T10038-.

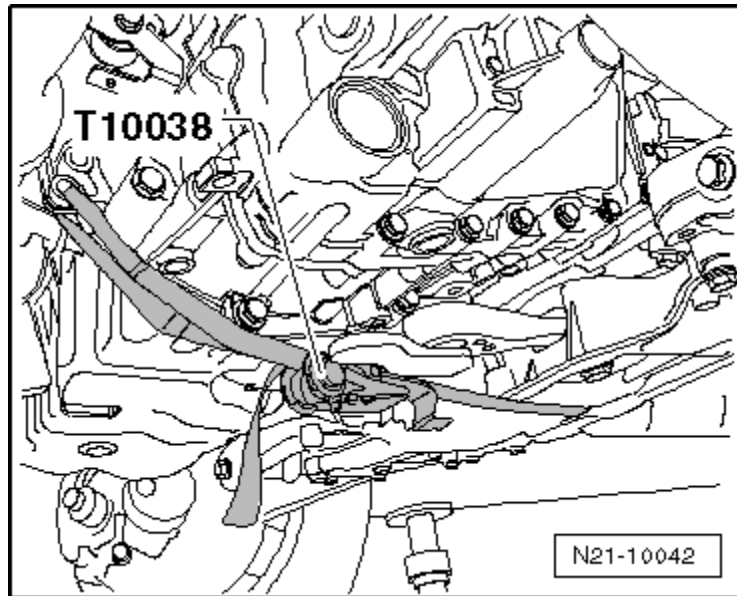

- Remove nuts -arrows-.
- Detach turbocharger from cylinder head.

Installation

Installation is carried out in the reverse order; note the following:



Note

- ◆ Replace the seals, the gaskets, O-rings and the self-locking nuts.
- ◆ Lubricate studs for turbocharger with high-temperature paste. For high-temperature paste refer to → [Electronic parts catalogue](#).
- ◆ Fill turbocharger with engine oil at connection for oil supply line.
- ◆ The brackets for the hoses and the supercharger air system tubes must be free from oil and grease for fitting.
- ◆ Secure all hose connections with the correct type of hose clips (same as original equipment) → [Electronic parts catalogue](#).
- Install front exhaust pipe with catalytic converter → [Chapter](#).
- Align the exhaust system so it is free of stress

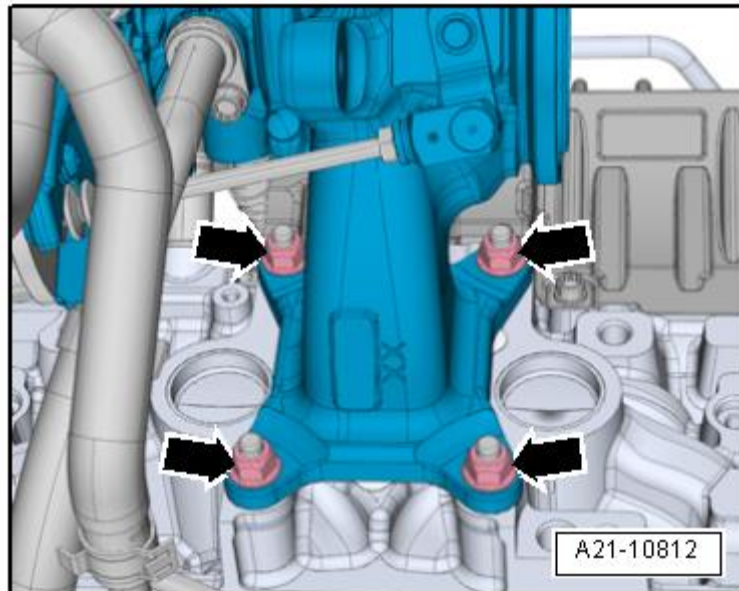

→ Chapter.

– Fill up with coolant

→ Anchor.

Check oil level

–

→ Booklet501.



Note

After installing turbocharger, allow engine to idle for approx. 1 minute and do not rev up immediately to ensure turbocharger is supplied with oil.

Tightening torques

- ◆ → Chapter „Turbocharger, exploded view“
- ◆ → Chapter „Air filter cartridge: Assembly overview“
- ◆ → Chapter „Lambda probe - overview“

2 IGNITION SYSTEM

2.1 Ignition system: Assembly overview

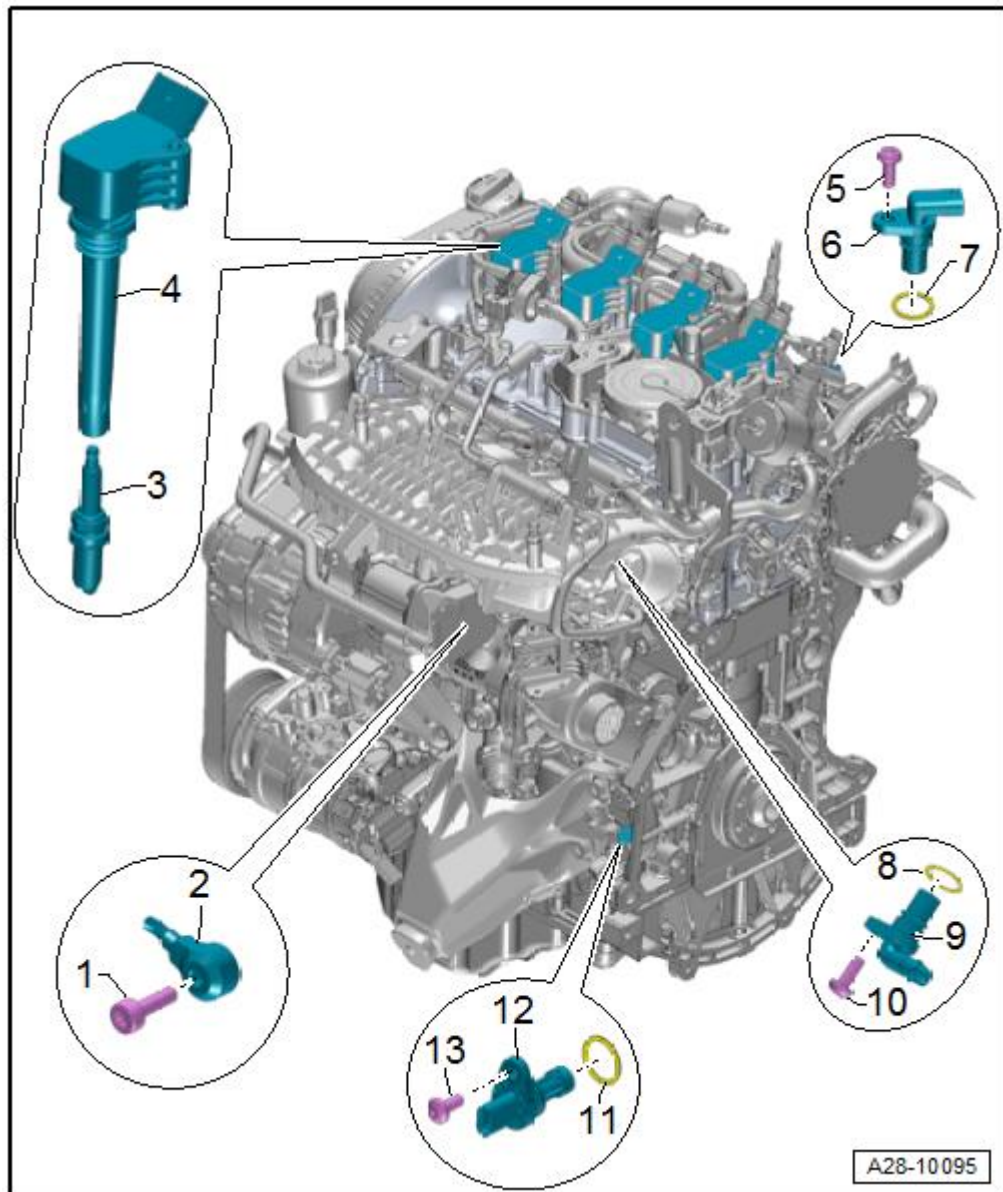

1 - Bolt

- replace
- 20 Nm.
- Tightening torque influences functions of knock sensor

2 - Knock sensor I -G61-

- remove and install → Chapter „Knock sensor 1 -G61-: Removing and installing“

3 - Spark plug

- 30 Nm.
- Remove and install with key -3122 B-

Intervals for changing filter

→ [Booklet 501](#)

4 - Ignition coil with output stage

- Ignition coil 1 with output stage -N70-
- Ignition coil 2 with output stage -N127-
- Ignition coil 3 with output stage -N291-
- Ignition coil 4 with output stage -N292-
- Tightening torque: 10 Nm
- remove and install → [Chapter „Ignition coils with output stage: removing and fitting“](#)

5 - Bolt.

- 9 Nm

6 - Hall sender 3 -G300-

- Removing and installing Hall sender 3 -G300- → [Chapter „Removing and installing Hall sender 3 -G300-“](#)
- Renew O-ring.

7 - O-ring

- Renew if damaged

8 - O-ring

- Renew if damaged

9 - Hall sender -G40-

- Removing and installing Hall sender -G40- → [Chapter „Removing and installing Hall sender“](#).

10 - Bolt

- 9 Nm

11 - O-ring

- Renew if damaged

12 - Engine speed sender -G28-

- Check O-ring for damage
- remove and install → [Chapter „Removing and installing engine speed sender -G28-“](#)

13 - Bolt

- 9 Nm

2.2 Ignition coils with output stage: removing and fitting

Special tools and workshop equipment required

- ◆ Extractor -T10530-

Removing

- Remove engine cover → [Chapter](#).
- If fitted, detach the earth cable.

Release connectors and unplug all connectors from the ignition coils at the same time.

- Unscrew the bolt for the ignition coil to be removed.

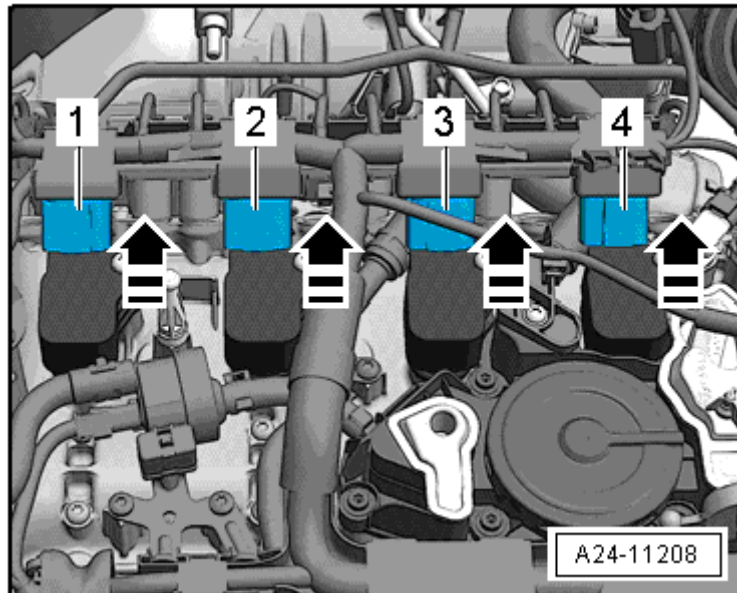

- Insert puller -T10530- into hole -1- in ignition coil.
- Turn knurled nut -2- clockwise until puller is secured in place.

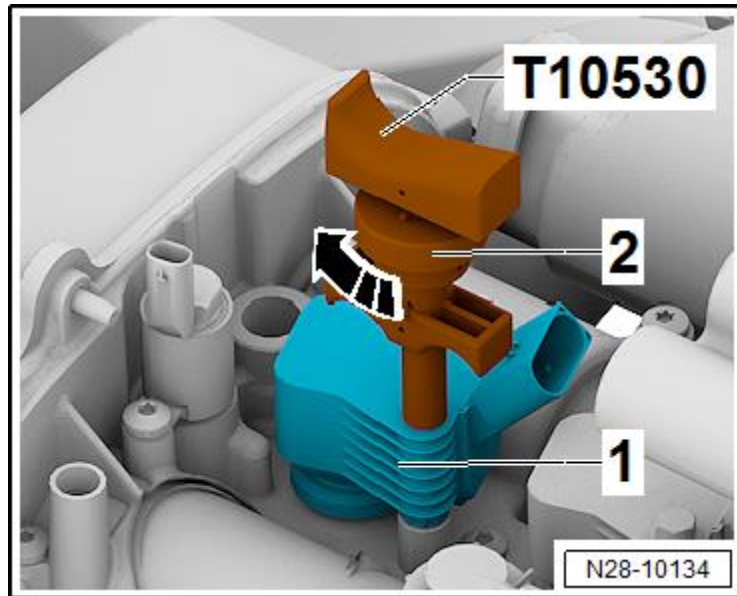

- Working vertically upwards, carefully pull ignition coil out with puller -T10530-.

Installation

- Press ignition coils onto spark plugs by hand evenly (do not use tools).
- Secure ignition coils.

Tightening torques

- ◆ → Chapter „Ignition system: Assembly overview“

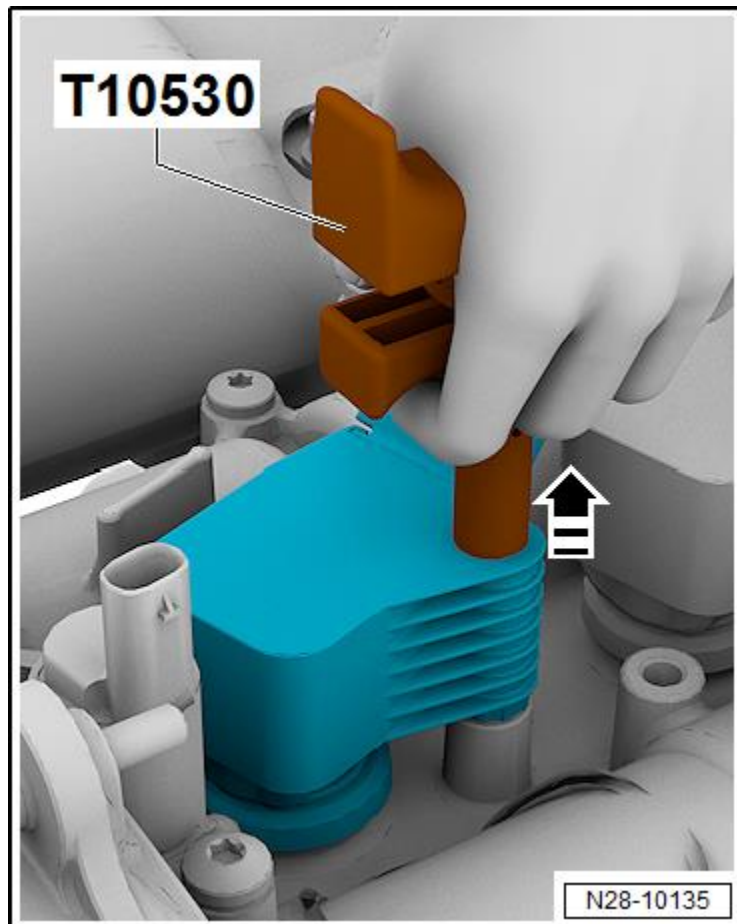

Nut	Tightening torque
Earth connection	9 Nm

3 OIL SUMP

3.1 Assembly overview - sump, oil pump



If large quantities of metal shavings or other particles are found in the engine oil when repairing the engine (possibly caused by partial seizure of crankshaft and conrod bearings), clean the oil passages thoroughly and renew the engine oil cooler to prevent further damage occurring later.

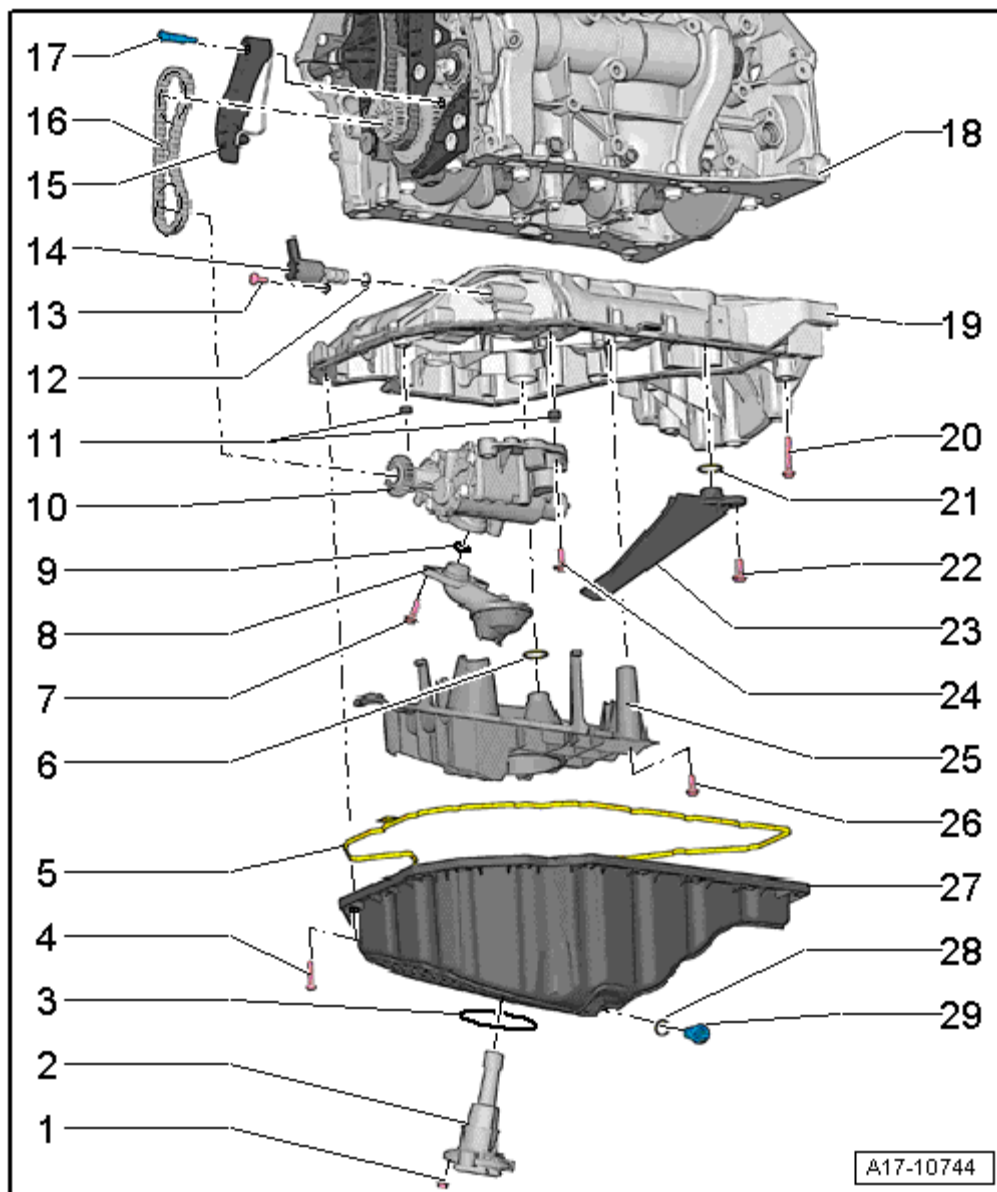

1 - Nut

- 9 Nm.

2 - Oil level and oil temperature sender -G266-

- remove and install → [Chapter](#)

3 - Seal

- Renew

4 - Bolt

- Renew
- Tightening sequence → [Fig.](#)

5 - Seal

- Only for sump (bottom section), sheet-metal version

6 - O-ring

- Renew
- Lubricate lightly with engine oil

7 - Bolt

- Renew
- 4 Nm and turn 45° further

8 - Suction pipe

- Clean strainer if soiled.

9 - O-ring

- Renew
- Lubricate lightly with engine oil

10 - Oil pump

- remove and install → [Chapter](#)

11 - Dowel sleeves

12 - O-ring

- Renew
- Lubricate lightly with engine oil

13 - Bolt

- Tightening torque → [Item](#)

14 - Valve for oil pressure control -N428-

- remove and install → [Chapter](#)

15 - Chain tensioner

16 - Chain for operating oil pump

- Mark direction of rotation before removing

17 - Bolt

- 9 Nm.

18 - Cylinder block

19 - Upper element on the case

- remove and install → [Chapter](#)

20 - Bolt

- Renew
- Tightening sequence → [Fig.](#)

21 - O-ring

- Renew
- Lubricate lightly with engine oil

22 - Bolt

- Renew
- 4 Nm + 45°

23 - Oil return line

24 - Bolt

- Renew
- 8 Nm +90°

25 - Baffle

- Renew

26 - Bolt

- Renew
- 4 Nm +45°

27 - Lower element on the case

- Different versions available → Electronic parts catalogue
- remove and install → [Chapter](#)

28 - Seal ring or O-ring

- Seal for sheet-metal version of sump (bottom section)
- O-ring for plastic version of sump (bottom section)
- Renew
- Lubricate O-ring with engine oil

29 - Oil drain plug or sealing plug

- Oil drain plug for sheet-metal version of sump (bottom section)
- Oil drain plug: 30 Nm
- Sealing plug for plastic version of sump (bottom section)
- Tighten sealing plug as far as stop

Tightening sequence for sump (bottom section), plastic version

 Note

Renew the bolts tightened with specified tightening angle.

– Tighten bolts -1 to 20- in 2 stages as shown in the sequence:

1. Tighten bolts to 8 Nm.
2. Turn bolts 90° further.

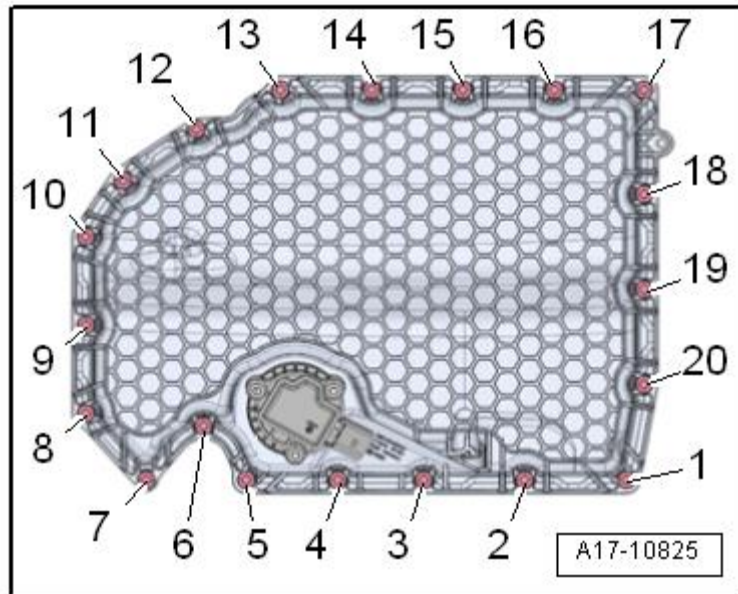

Tightening sequence for sump (bottom section), sheet-metal version

 Note

Renew the bolts tightened with specified tightening angle.

– Tighten bolts -1 to 20- in 2 stages as shown in the sequence:

- 1. Tighten bolts to 8 Nm.
- 2. Turn bolts 45° further.

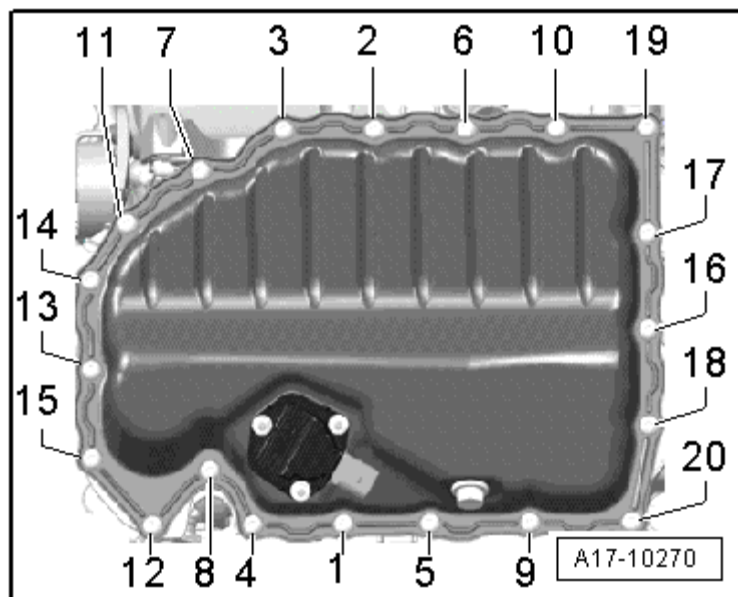

Upper element of the oil tray, tightening sequence

 Note

Renew the bolts tightened with specified tightening angle.

– Tighten bolts -1 to 14- in the sequence shown.

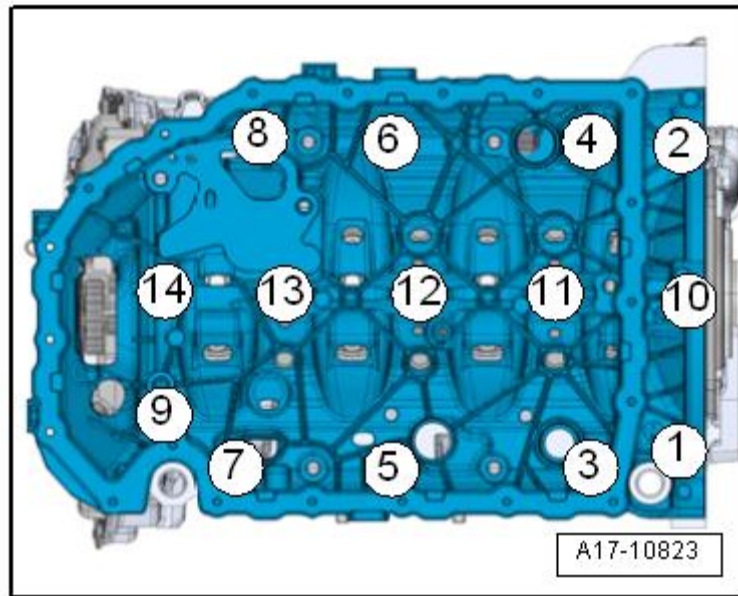

stage:	Tightening sequence and tightening torque
1. Bolts -1- to -14-	Tighten to 8 Nm
2. Bolts -1- and-2-	turn 180° further
3. Bolts -3- to -9-	turn 45° further
4. Bolt -10-	turn 180° further
5. Bolts -11- to -14-	turn 90° further

3.2 Removing and installing oil level/oil temperature sender - G266-

Removing

Engine oil drained

- → [Booklet501](#).
- Pull out the plug -3-.
- Unscrew nuts -1- and remove oil level and oil temperature sender - G266--Pos. 4. 4-.

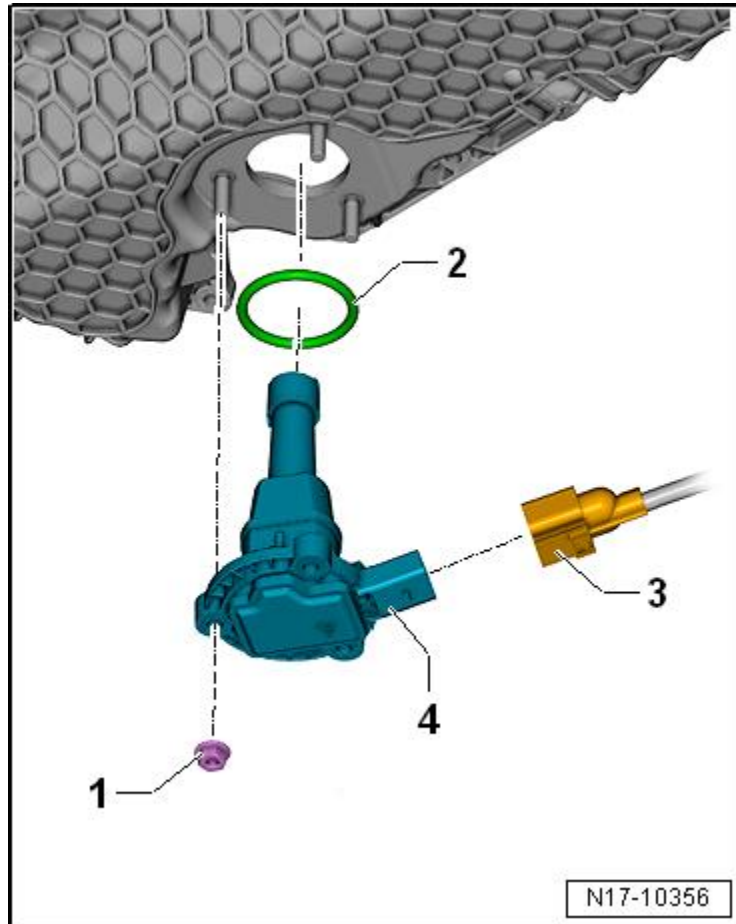

Installing
Installation is carried out in the reverse order; note the following:



Note

Renew seal -2-.

Fill up with engine oil and check the oil level

→ [Booklet501](#).

Tightening torques

→ Chapter „Assembly

- ◆ overview - sump, oil pump“

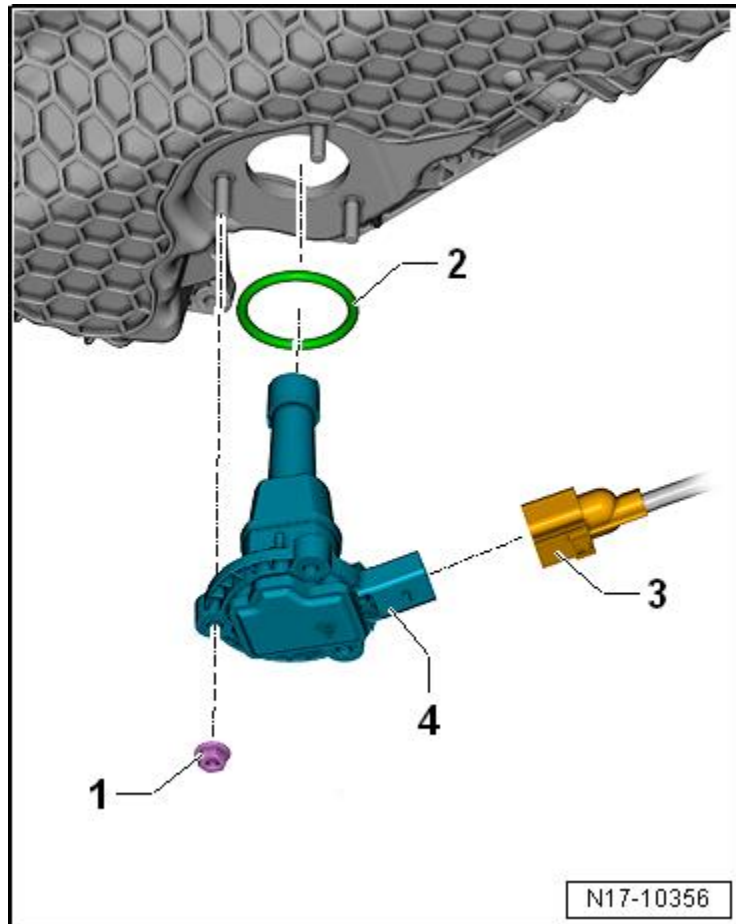

3.3 Remove and install the lower element of the oil tray

Special tools and workshop equipment required

- ◆ Used oil collection and extraction unit -VAS 6622A-
- ◆ Electric drill with plastic brush attachment
- ◆ Protective glasses
- ◆ Silicone sealant:
→ [Electronic parts catalogue](#)

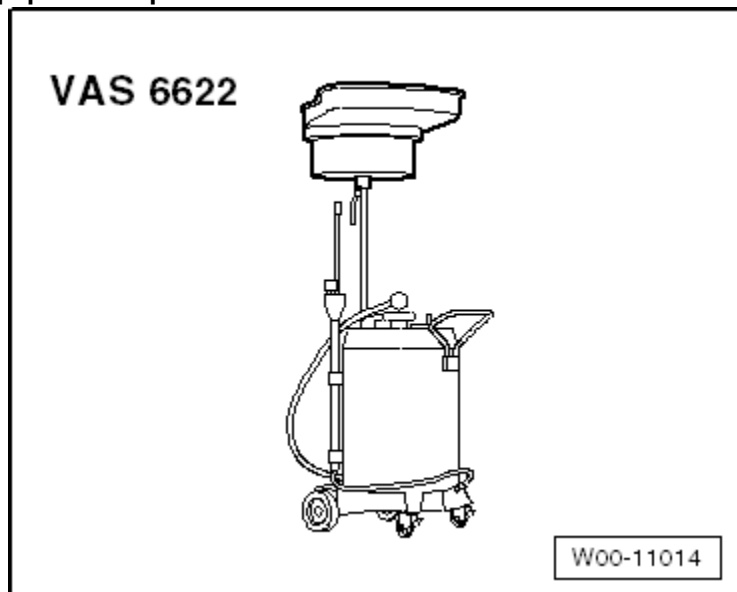

Removing

- Remove the sound proofing -1-

→ Rep. gr.66.

- Place the used oil collection and extraction unit -VAS 6622A- underneath the engine and allow the oil to drain.



Note

Please observe requirements for disposal.

- Remove oil level and oil temperature sender - G266- → Chapter.

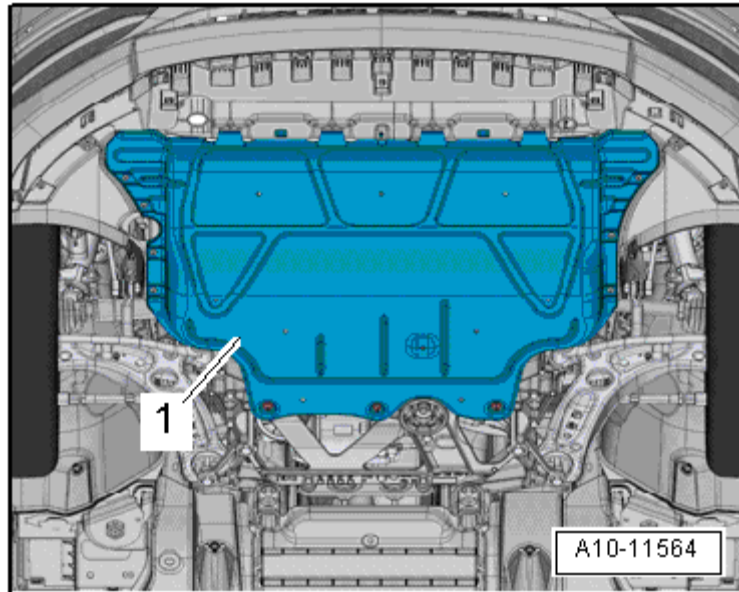

Vehicles with plastic version of sump (bottom section):

- Remove bolts -1 ... 20-
- Detach sump (bottom section).

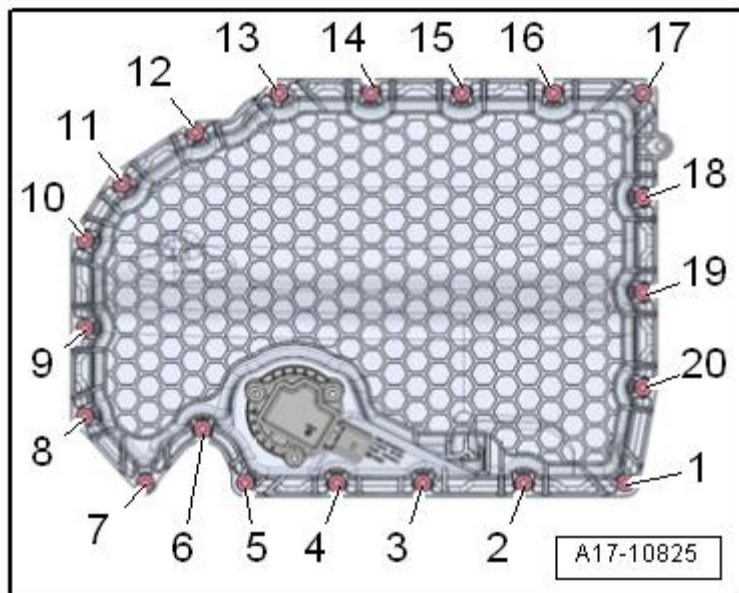

Vehicles with sheet-metal version of sump (bottom section):

- Remove bolts -1 ... 20-. Carefully release sump (bottom section) from bonded joint.

Installation

Sump (bottom section), sheet-metal version:



Note

- ◆ Observe use-by date of the silicone sealant. The sump must be installed within 5 minutes after applying the silicone sealant.
- ◆ Replace bolts that are tightened with specified tightening angle.
- ◆ Renew seals, gaskets and self-locking nuts.
- Spray sealing surface with sealant remover and wait for it to take effect.
- Remove sealant remaining on sump (top section) with flat scraper.



WARNING

Risk of eye injury.

Wear safety goggles!

- Remove sealant residue on sump (bottom section) using rotating plastic brush or similar.
- Clean sealing surfaces; they must be free of oil and grease.

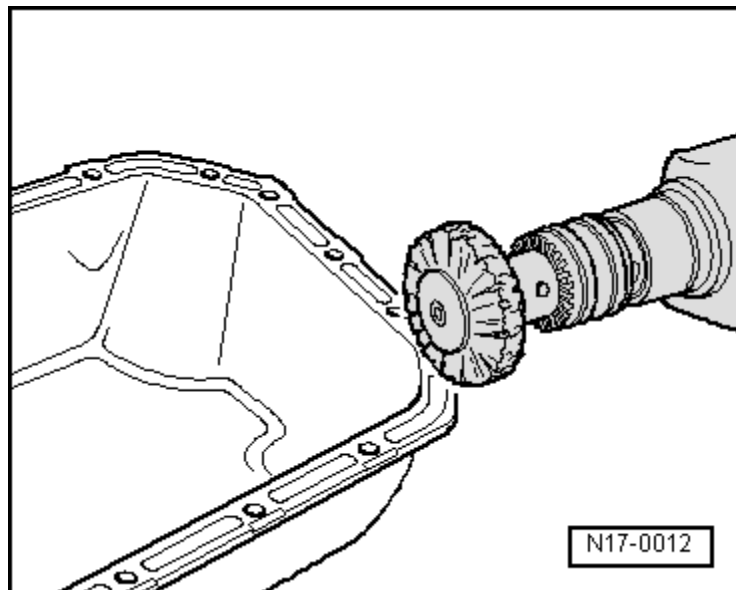
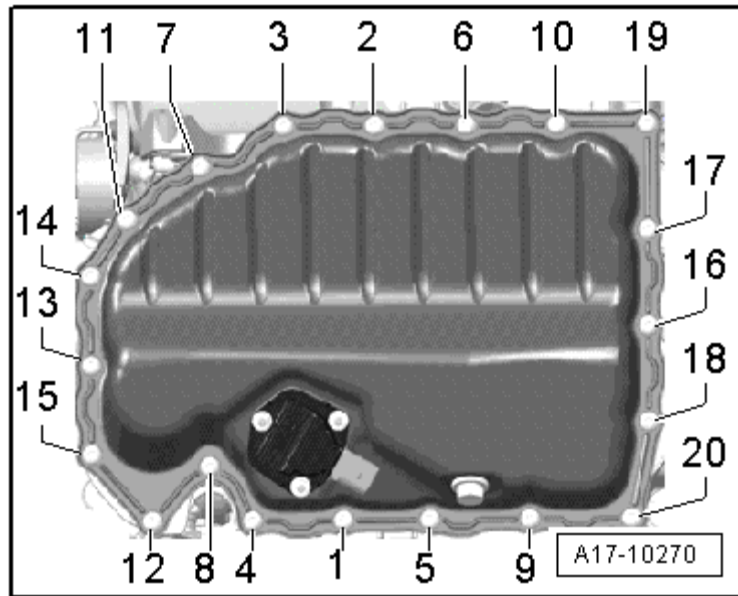

- Cut off tube nozzle at front marking (Ø of nozzle approx. 3 mm).

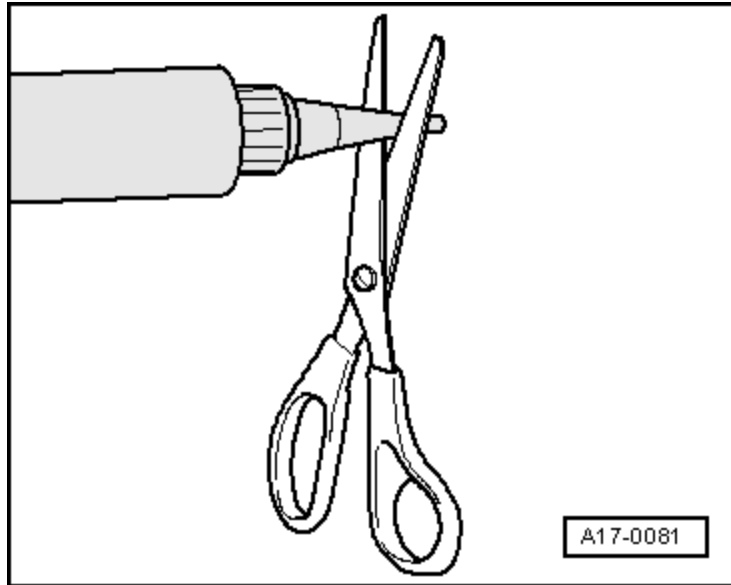

- Apply a line of silicon sealant, as shown in the figure, to the clean surface of the oil sump seal.
- ◆ Thickness of the sealing paste bead: 2 ... 3 mm
-  Note
 - ◆ The sump must be installed within 5 minutes after applying the silicone sealant.
 - ◆ The line of sealant must not be thicker than prescribed, as otherwise excessive sealant will enter the sump and obstruct the strainer in the oil intake pipe.

 Note

Let sealing compound dry for approx. 30 minutes after installing oil sump. Only then may engine oil be filled in.

- Immediately fit sump (bottom section) and tighten bolts; tightening sequence → Fig..

Continuation for all vehicles:

Fill up with engine oil and check the oil level

- → [Booklet501](#).

Tightening torques

- ◆ → [Chapter „Assembly overview - sump, oil pump“](#)

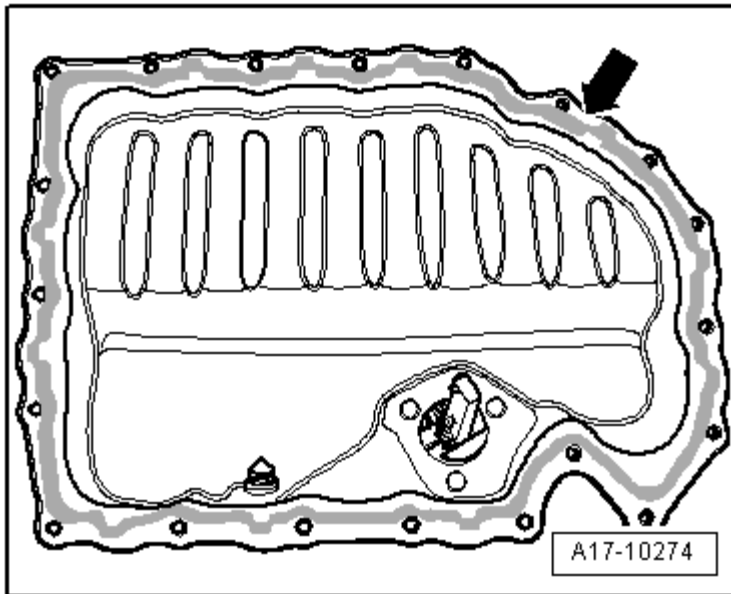

3.4 Remove and install the upper element of the oil tray

Special tools and workshop equipment required

- ◆ Pinning tool -T10118-

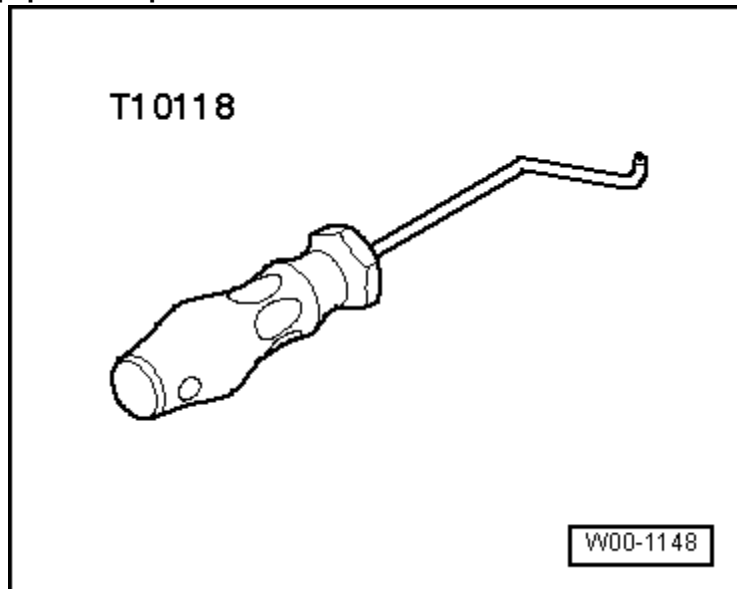

- ◆ Pinning tool -T40265-
- ◆ Electric drill with plastic brush
- ◆ Protective glasses
- ◆ Silicone sealant:
→ [Electronic parts catalogue](#)

Removing

- Gearbox is removed.
- Remove sump (bottom section) → [Chapter](#).
- Remove rear sealing flange → [Chapter](#).
- Remove oil pump → [Chapter](#).

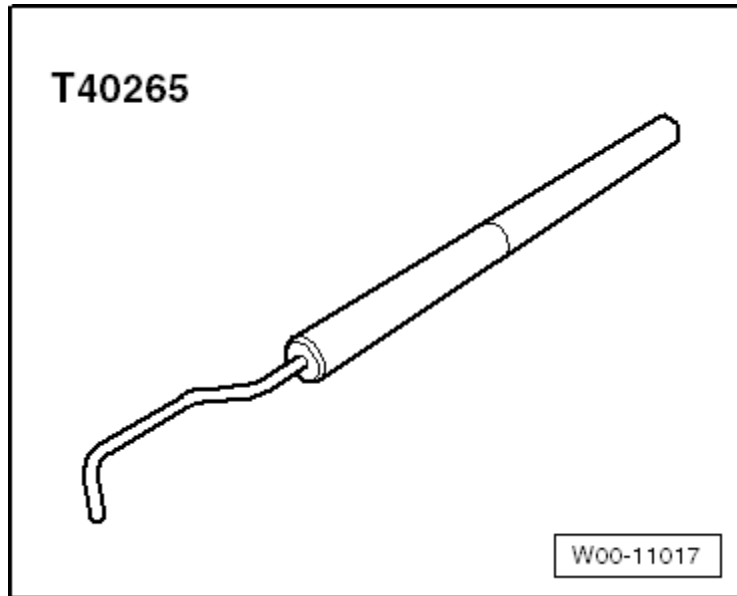

Vehicles with auxiliary radiator (left-side)

- Remove washer fluid reservoir

→ [Rep. gr.92](#).

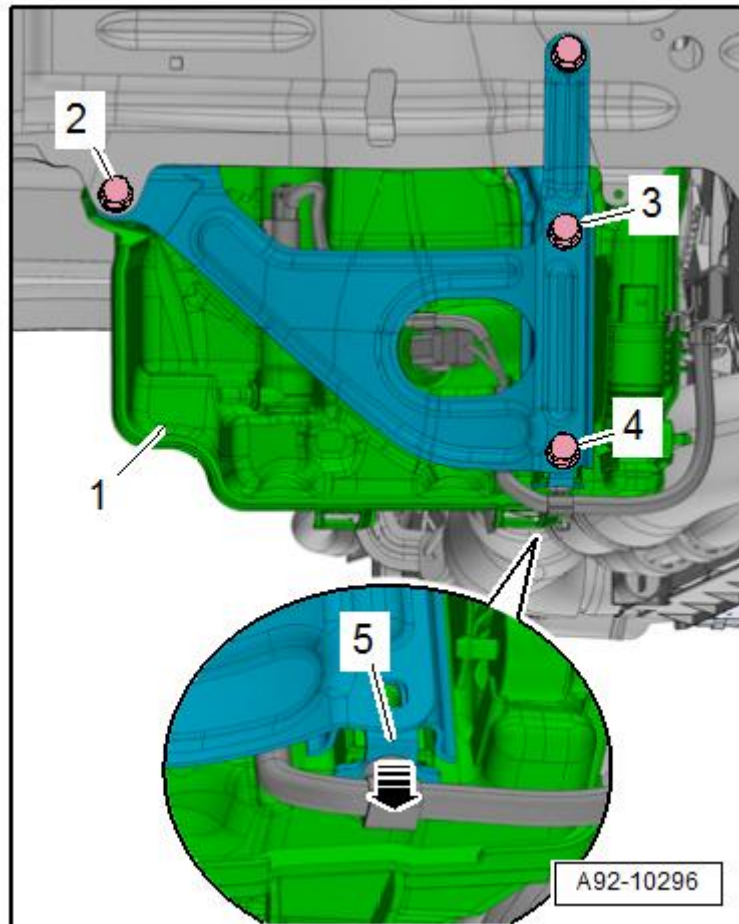

Continuation for all vehicles:

- Unplug connector -1-.

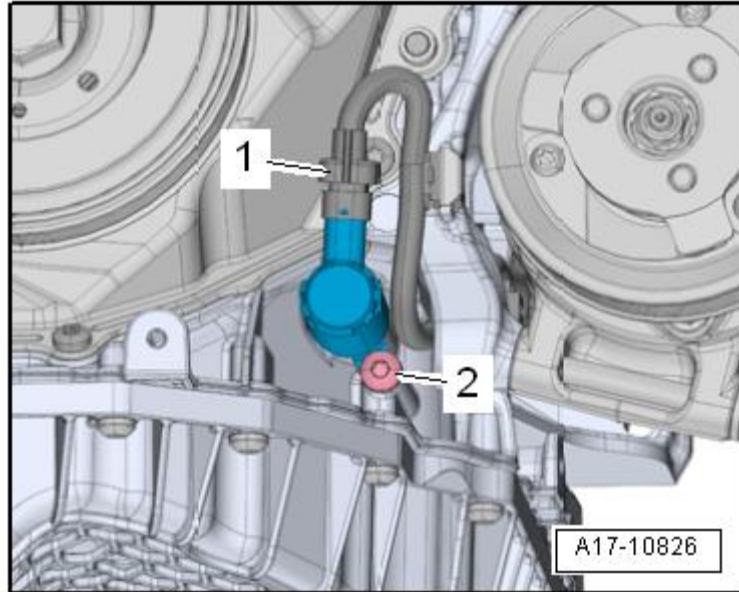

- Remove bolts -arrows-.

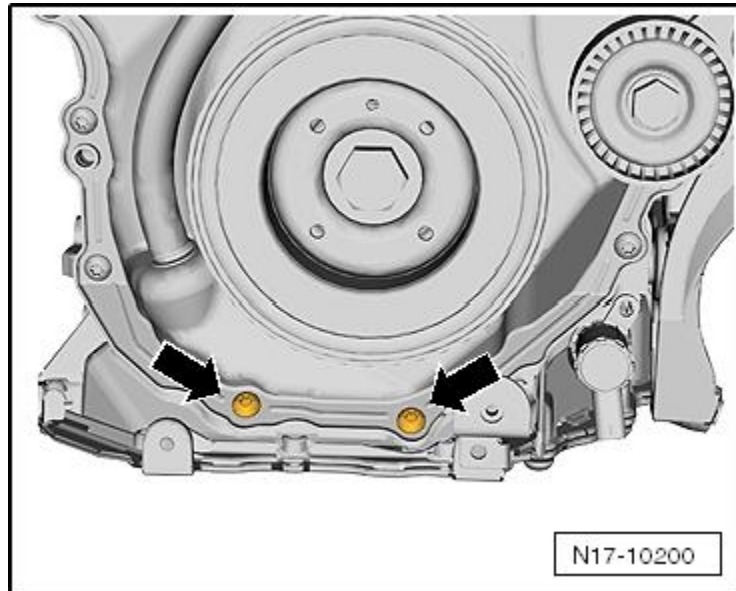

- Unscrew bolts -1 to 14- and remove the upper part of the sump.



Caution

First lift the top part of the oil pan onto the side of the gearbox. Take care timing chain cover is not bent when levering off.

Installation

Silicone sealant

- ◆ → [Electronic parts catalogue](#).



Note

- ◆ Observe use-by date of the silicone sealant.
- ◆ The sump (top section) must be installed within 5 minutes after applying the silicone sealant.
- ◆ Replace bolts that are tightened with specified tightening angle.
- ◆ Renew seals, gaskets and self-locking nuts.
- ◆ Remove sealant residue from cylinder block using a flat scraper.



WARNING

Risk of eye injury.

Wear safety goggles!

Remove sealant residue on

- sump (top section) using rotating plastic brush or similar.



Note

Check if timing chain cover is deformed. For this purpose, first fit sump (top section) without sealant and determine gap between cover and sump (top section). If the cover is deformed and cannot be straightened, renew cover after installing sump (top section).

Clean sealing surfaces; they must be free of oil and grease.

- Check oil passages in sump (top section) and crankcase for contamination.

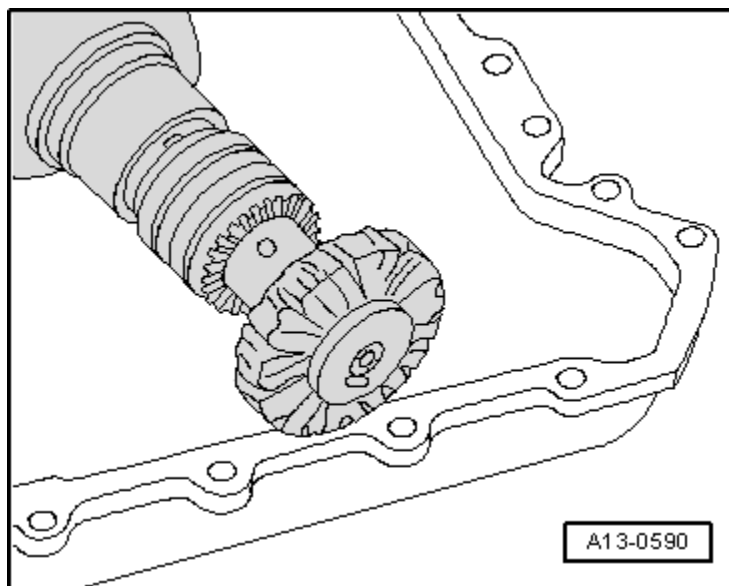
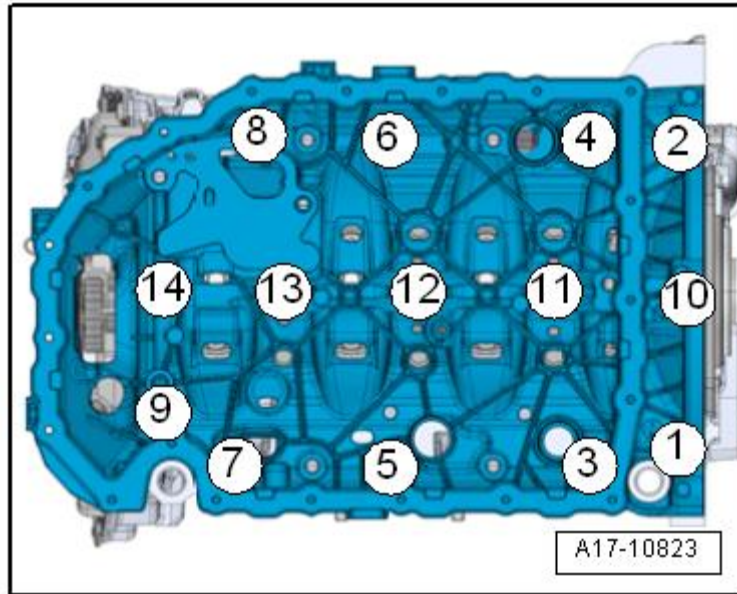

- Cut off tube nozzle at front marking (Ø of nozzle approx. 2 mm).

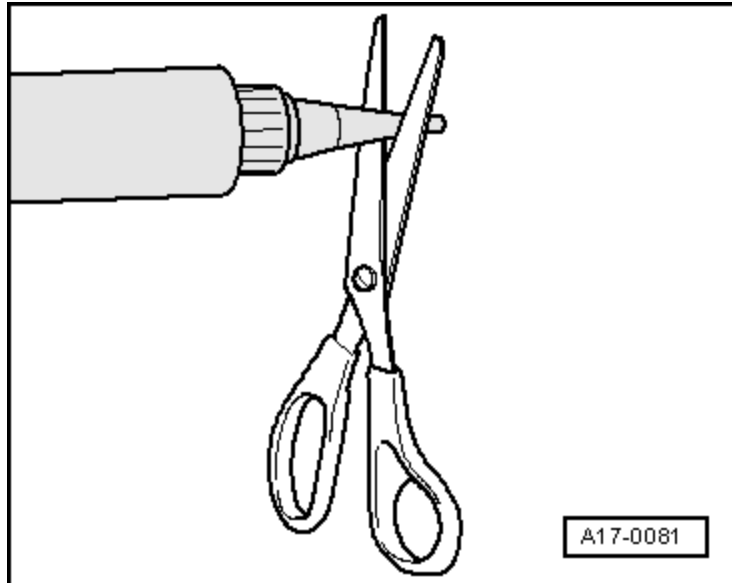

Caution

Danger of blocking lubrication system with excess sealant.
Do not apply sealant bead thicker than specified.

- ◆ Thickness of the sealant bead: 2 to 3 mm.
Apply silicone sealant onto clean sealing surface of sump (top section) as illustrated -arrow-.
-

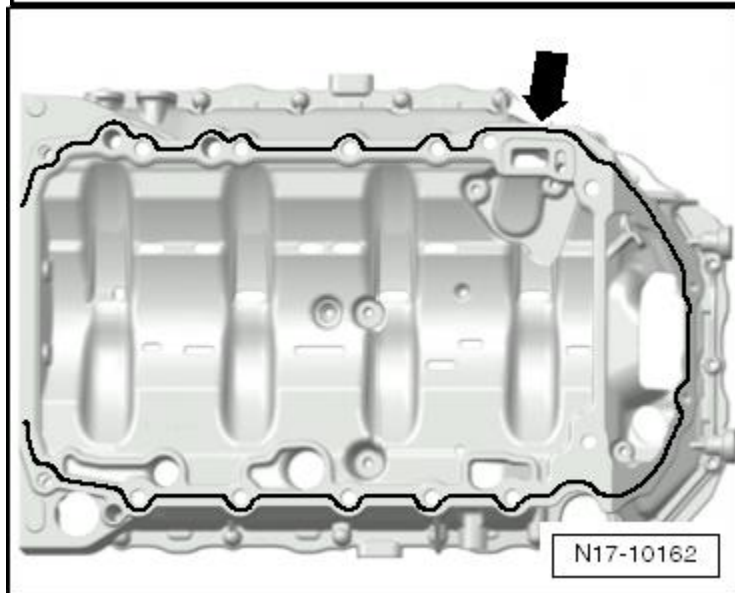

Apply silicone sealant between cylinder block and timing chain cover (bottom), as illustrated - arrows-.



Note

There is a 5-minute time limit for fitting the upper part of the sump once the silicone sealant has been applied.

- ◆ The line of sealant must not be thicker than prescribed, as otherwise
- ◆ excessive sealant will enter the sump and obstruct the strainer in the oil intake pipe.
- Sump (top section) and crankcase must be flush at gearbox end.
- Immediately fit sump (top section) and tighten bolts, tightening torque → Fig.

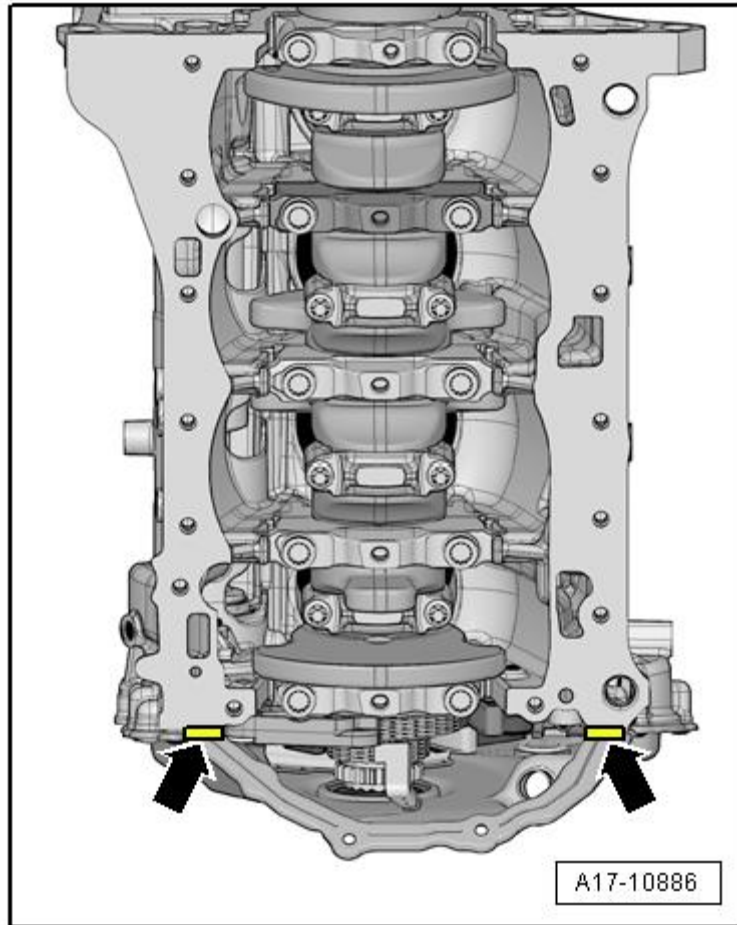

- Fit bolts -arrows-. Tightening torques → Item
- Install rear sealing flange → Chapter.
- Install oil pump → Chapter.
- Fit new baffle plate and secure in position.
- Install sump (bottom section) → Chapter.
- Install washer fluid reservoir
- → Rep. gr.92.

Further assembly is basically carried out in reverse order of dismantling.

Fill up with engine oil and check the oil level

→ Booklet501.

Tightening torques

- ◆ → Chapter „Assembly overview - sump, oil pump“

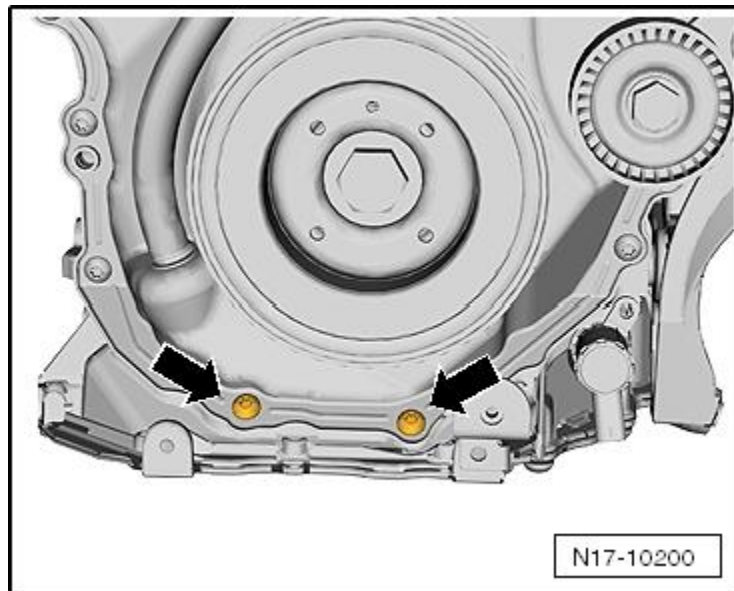

4 INTAKE MANIFOLD WITH THROTTLE

4.1 Intake manifold: Assembly overview

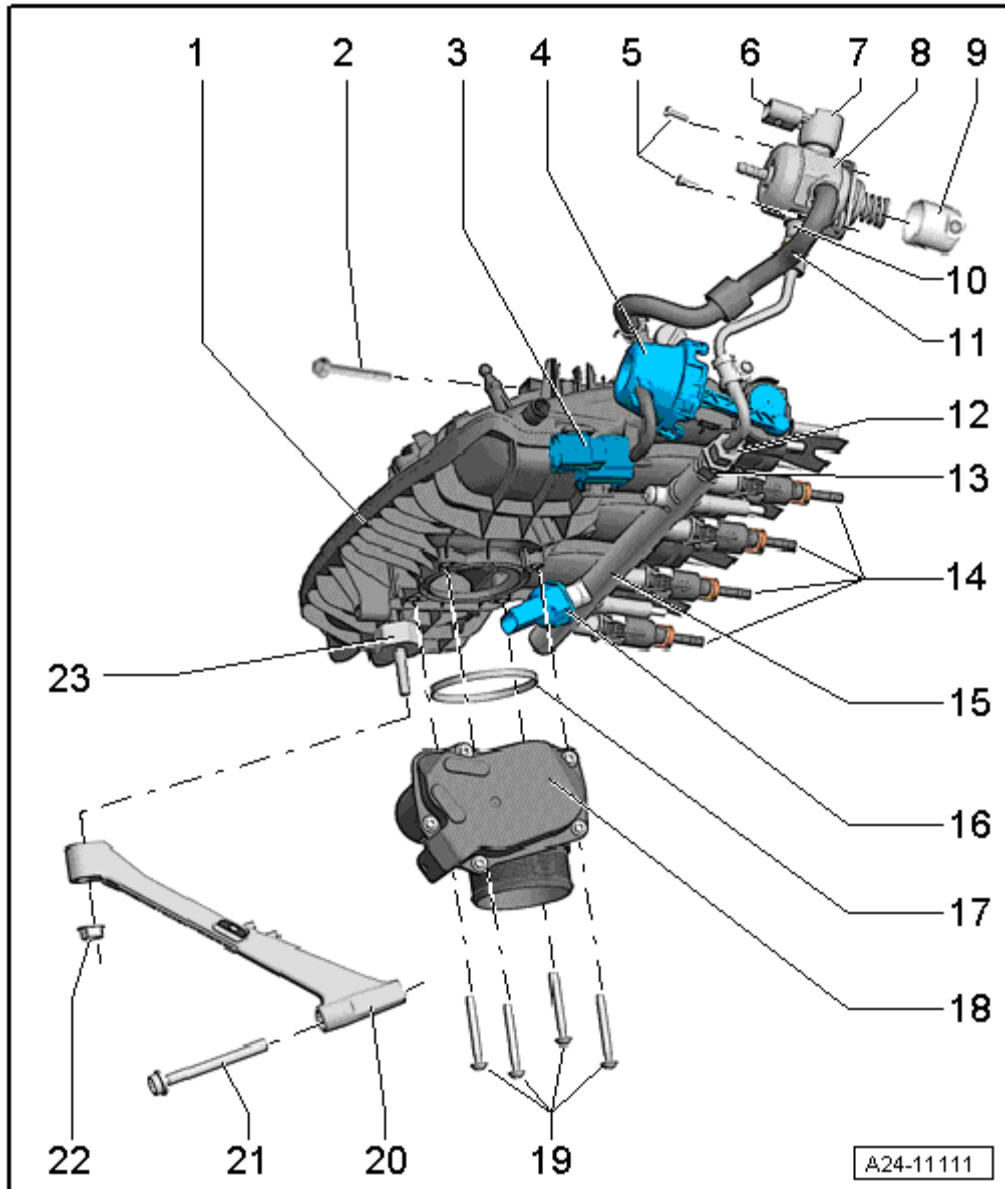

- 1 - Intake manifold
 - remove and install → Chapter
- 2 - Bolt for intake manifold
 - 9 Nm.
- 3 - Intake manifold flap valve -N316-
- 4 - Vacuum unit for air flow control flaps (intake manifold flaps)
- 5 - Bolts for the high-pressure pump .
 - Renew
 - Hand-tighten in diagonal sequence, then tighten to 8 Nm + 90° further
- 6 - Electrical connector
 - for the Fuel pressure regulating valve -N276-

- 7 - Fuel pressure regulator valve -N276-
- 8 - High-pressure pump
 - With fuel pressure regulating valve -N276-
 - An electric fuel pump (fitted in fuel tank) supplies fuel to the mechanical high-pressure pump
 - When fitting the high pressure pump, take care that no dirt enters the fuel system.
 - Take care to protect the high-pressure pump from knocks
 - The fuel system must not be under pressure when installing the high-pressure pump;
 - procedure for reducing fuel pressure → Chapter „Reducing fuel pressure in high-pressure section“
 - Fuel pipes must be free of tension when installed.
 - remove and install → Chapter
- 9 - Roller tappet
 - May remain lodged inside vacuum pump after removal of high-pressure pump, but can be removed
- 10 - Fuel supply line
 - to fuel rail for combustion chamber injectors
 - Lightly lubricate ball of fuel supply line with engine oil
 - Fuel supply pipe must be free of tension when installed (make sure all parts are clean)
- 11 - Fuel supply line
 - to fuel rail for intake manifold injectors
 - Fuel supply pipe must be free of tension when installed (make sure all parts are clean)
- 12 - Union nut for fuel supply line
 - 20 Nm
- 13 - Connection for fuel supply line
 - Renew
 - Lubricate threads lightly with clean engine oil
 - 40 Nm.
- 14 - Injectors
 - Renew O-ring and Teflon ring
 - Ensure correct installation position
 - remove and install → Chapter „Removing and installing combustion chamber injectors“
- 15 - Fuel rail for FSI injectors
- 16 - Fuel pressure sender -G247-
 - 27 Nm.
 - Lubricate threads lightly with clean engine oil
 - remove and install → Chapter „Removing and installing fuel pressure sender -G247-“
- 17 - Oil seal
 - Renew
- 18 - Throttle valve module -GX3-
 - comprising:
 - Throttle valve drive (electric power control) -G186-
 - Throttle valve drive angle sender 1 (electric power control) -G187-
 - Throttle valve drive angle sender 2 (electric power control) -G188-
 - after replacement or after removal and installation, throttle valve control unit -GX3- must be adapted to engine control unit -J623- → Vehicle diagnostic tester
- 19 - Bolt for throttle valve module -GX3-
 - 7 Nm.
- 20 - Intake manifold support
- 21 - Bolt
 - For intake manifold support
 - 20 Nm.

22 - Intake manifold support nut

- 10 Nm.

23 - Rubber mounting

- 5 Nm

4.2 Exploded view - fuel rail, direct injection

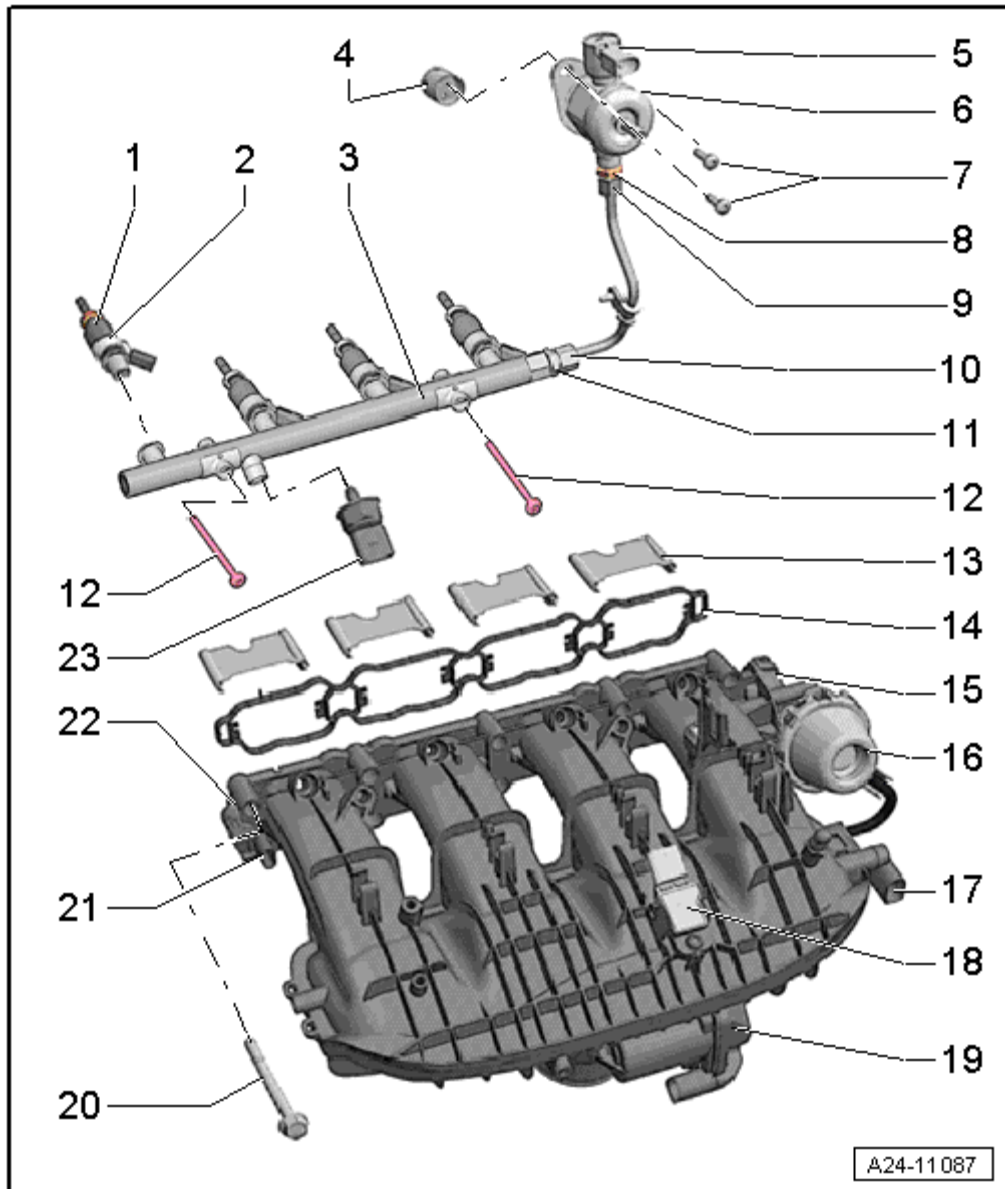

1 - Injector

- With combustion chamber ring seal (Teflon ring seal): always renew
- Replace the O-rings.
- Ensure correct installation position
- removing and fitting → Chapter

2 - Pressure rings

- Renew
- 3 - Fuel rail for combustion chamber injectors
 - tighten to 9 Nm
 - removing and fitting → Chapter
- 4 - Roller tappet
- 5 - Fuel pressure regulator valve -N276-
- 6 - High-pressure pump
 - With fuel pressure regulating valve -N276-
 - An electric fuel pump (fitted in fuel tank) supplies fuel to the mechanical high-pressure pump
 - When fitting the high pressure pump, take care that no dirt enters the fuel system.
 - The fuel system must not be under pressure when installing the high-pressure pump; procedure for reducing fuel pressure → Chapter
 - Fuel pipes must be free of tension when installed.
 - removing and fitting → Chapter
- 7 - Bolts for the high-pressure pump .
 - Renew
 - Tighten evenly.
 - 20 Nm.
- 8 - Connecting piece for fuel supply line at high-pressure pump
 - Renew
 - 40 Nm.
- 9 - Union nut for fuel supply line
 - Lightly lubricate ball of fuel supply line with engine oil
 - 20 Nm
- 10 - Union nut for fuel supply line
 - Lightly lubricate ball of fuel supply line with engine oil
 - 20 Nm
- 11 - Connecting piece for fuel supply line at fuel rail
 - Renew
 - 40 Nm.
- 12 - Bolts
 - 9 Nm.

- 13 - Port separator plates
- 14 - Seal
 - Check for damage and renew if necessary
- 15 - Adjuster for air flow control flaps (intake manifold flaps)
- 16 - Vacuum unit for air flow control flaps (intake manifold flaps)
- 17 - Intake manifold flap valve -N316-
- 18 - Intake manifold sender -GX9-
 - comprising:
 - Intake air temperature sender -G42-
 - Intake manifold pressure sender -G71-
 - 5 Nm.
- 19 - Throttle valve module -GX3-
 - comprising:
 - Throttle valve drive (electric power control) -G186-
 - Throttle valve drive angle sender 1 (electric power control) -G187-
 - Throttle valve drive angle sender 2 (electric power control) -G188-
 - after replacement or after removal and installation, throttle valve control unit -GX3- must be adapted to engine control unit -J623- → [Vehicle diagnostic tester](#)
- 20 - Bolt for intake manifold
 - 9 Nm.
- 21 - Intake manifold flap potentiometer -G336-
 - After replacement or after removal and installation, intake manifold flap potentiometer -G336- must be re-adapted to engine control unit -J623- → [Vehicle diagnostic tester](#)
- 22 - Intake manifold
 - removing and fitting → [Chapter](#)
- 23 - Fuel pressure sender -G247-
 - Lubricate taper lightly with clean engine oil; do not lubricate thread
 - 22 Nm
 - removing and fitting → [Chapter](#)

4.3 Exploded view - fuel rail, intake manifold injection

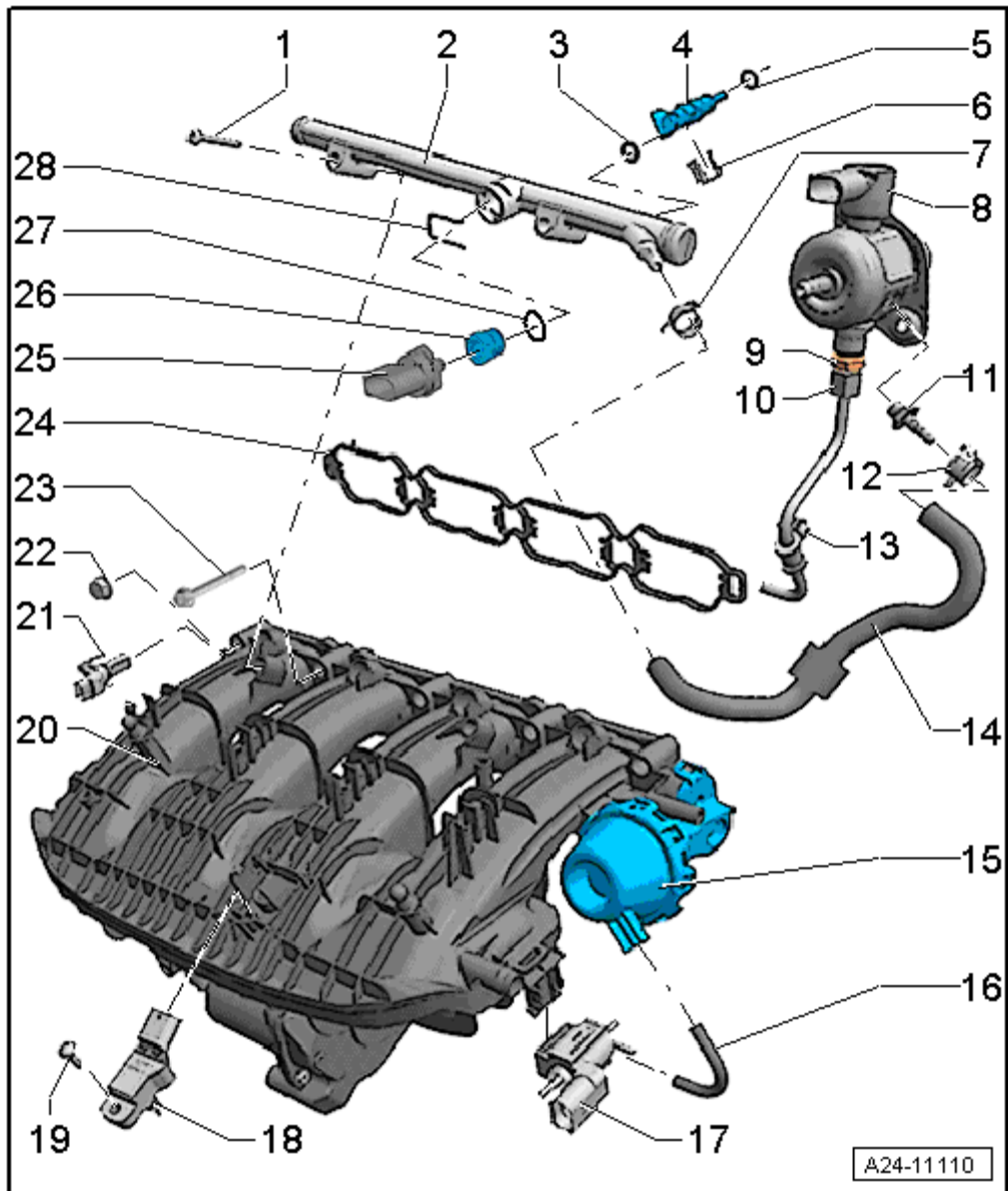

- 1 - Bolt
 - for fuel rail for intake manifold injectors
 - 9 Nm.
- 2 - Fuel rail for intake manifold injectors
- 3 - O-ring
 - Renew
- 4 - Injector
 - Replace the O-rings.
 - Ensure correct installation position
 - removing and fitting → Chapter
- 5 - O-ring
 - Renew
- 6 - Retaining clip
- 7 - Spring type clip

- 8 - High-pressure pump
 - With fuel pressure regulating valve -N276-
 - An electric fuel pump (fitted in fuel tank) supplies fuel to the mechanical high-pressure pump
 - When fitting the high pressure pump, take care that no dirt enters the fuel system.
 - The fuel system must not be under pressure when installing the high-pressure pump; procedure for reducing fuel pressure → **Chapter**
 - Fuel pipes must be free of tension when installed.
 - removing and fitting → **Chapter**
- 9 - Connecting piece for fuel supply line
 - replace
 - 30 Nm
- 10 - Union nut for fuel supply line
 - Fuel supply line to fuel rail for combustion chamber injectors
 - Lightly lubricate ball of fuel supply line with engine oil
 - Fuel supply pipe must be free of tension when installed (make sure all parts are clean)
 - 27 Nm
- 11 - Fuel supply line connection
 - 20 Nm
- 12 - Clamp
 - Renew
- 13 - Bolt
 - 5 Nm.
- 14 - Fuel supply line
 - Fuel supply line to fuel rail for intake manifold injectors
 - Fuel supply pipe must be free of tension when installed (make sure all parts are clean)
- 15 - Vacuum unit for air flow control flaps
- 16 - Vacuum hose
- 17 - Intake manifold flap valve -N316-
- 18 - Intake manifold sender -GX9-
 - comprising:
 - Intake air temperature sender -G42-
 - Intake manifold pressure sender -G71-
- 19 - Bolt
 - 5 Nm.
- 20 - Intake manifold
 - removing and fitting → **Chapter**
- 21 - Intake manifold flap potentiometer -G336-
 - After replacement or after removal and installation, intake manifold flap potentiometer - G336- must be adapted to engine control unit -J623- → **Vehicle diagnostic tester**
- 22 - Nut for intake manifold
 - 9 Nm.
- 23 - Bolts for intake manifold
 - 9 Nm.
- 24 - Seal
 - Check for damage and renew if necessary
- 25 - Fuel pressure sender (low pressure) -G410-
 - Tighten with adapter, -item 26-
 - 15 Nm.
 - removing and fitting → **Chapter**
- 26 - Adapter
 - Must be screwed onto fuel pressure sender for low pressure -G410-

- Renew O-ring.
- 15 Nm.
- 27 - O-ring
 - Renew
- 28 - Clamp
 - For securing fuel pressure sender for low pressure -G410- in fuel rail

4.4 Intake manifold: Removing and installing

Special tools and workshop equipment required

- ◆ Pinning tool -T10118-

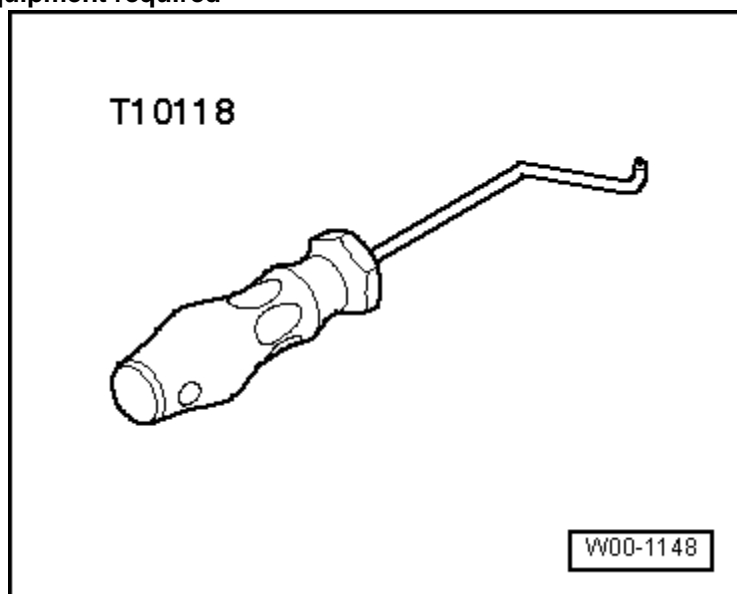

- ◆ Hose clip pliers -V.A.G 1921-

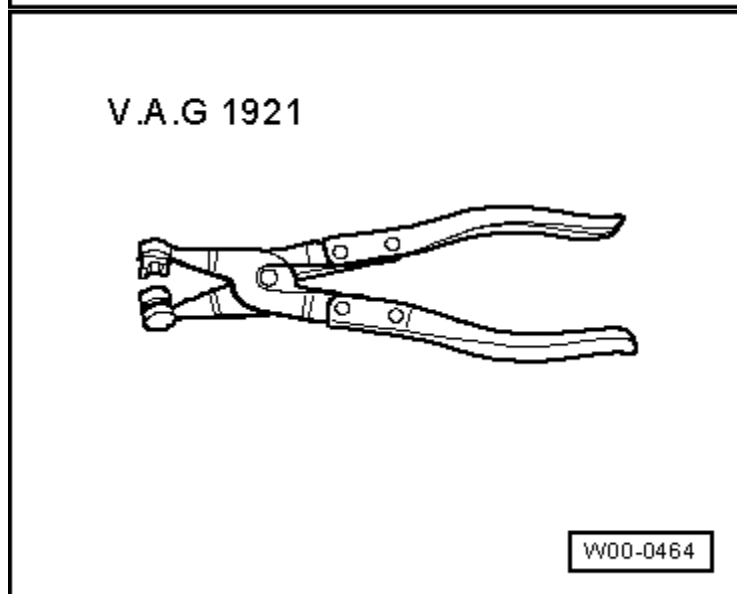

- ◆ Socket -T10347-
After the intake manifold has been removed or renewed, the intake manifold flap potentiometer -G336- must be adapted to the engine control unit -J623-.
- Removing



Caution

Risk of severe damage to the electronic components when disconnecting the battery.

- Observe notes on
- ◆ procedure for disconnecting the battery.
- Only disconnect battery when the ignition is
- ◆ switched off

→ Rep. gr.27.

Disconnect battery

-
- Rep. gr.27.
- Remove engine cover
- Chapter.
- Remove bolts -arrows- for coolant line from intake manifold.
- Remove the air filter housing → Chapter.

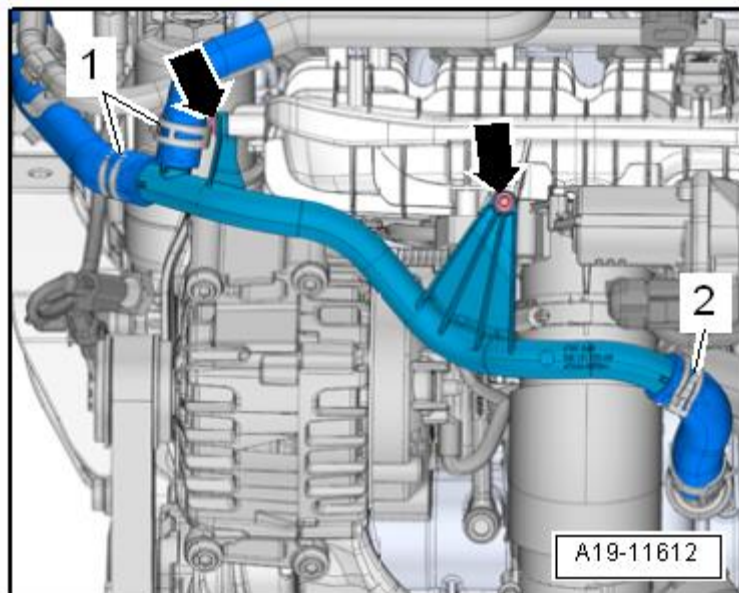
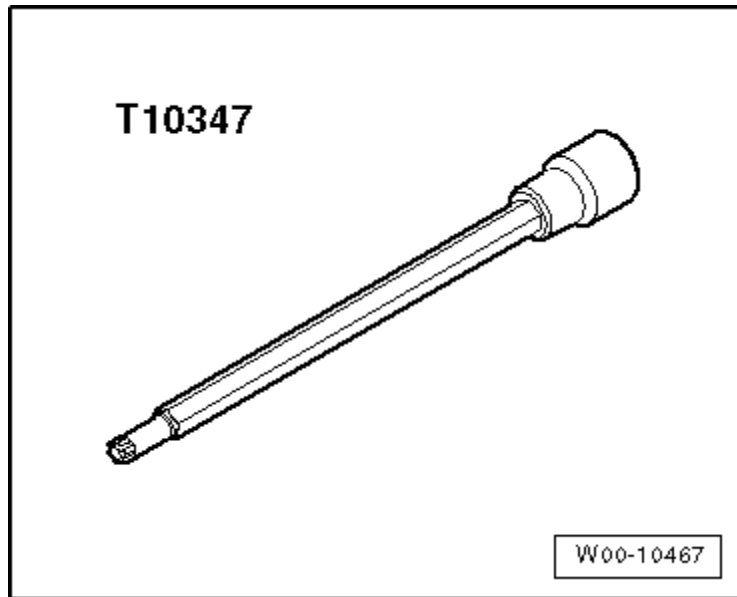

- Screw out left and right-hand bolts -arrow-.
- Unclip air duct (bottom section) -1- and detach.
- Remove the sound proofing -1-

→ Rep. gr.66.

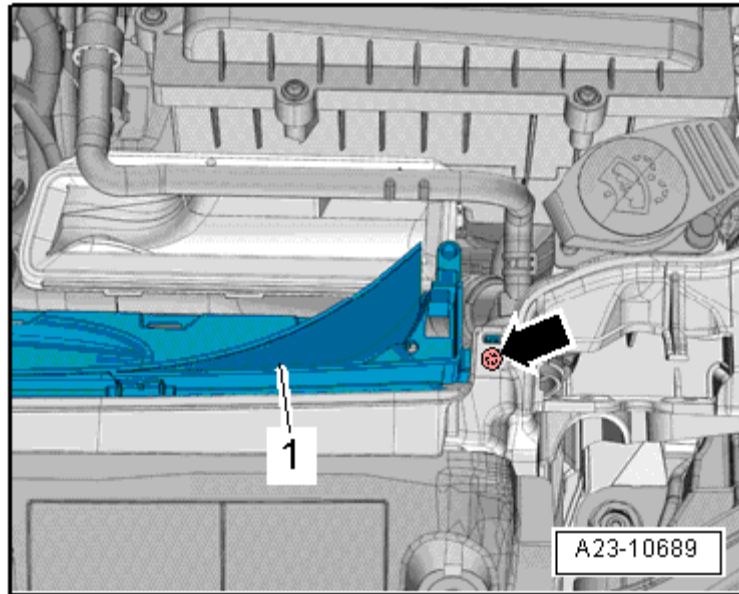

- Free coolant hose -3-.
- Unplug electrical connector -1- at charge pressure sender -G31-.
- Remove bolts -arrows-.
- Loosen hose clip -2- on air hose and pull air hose downwards off throttle valve module -J338-.

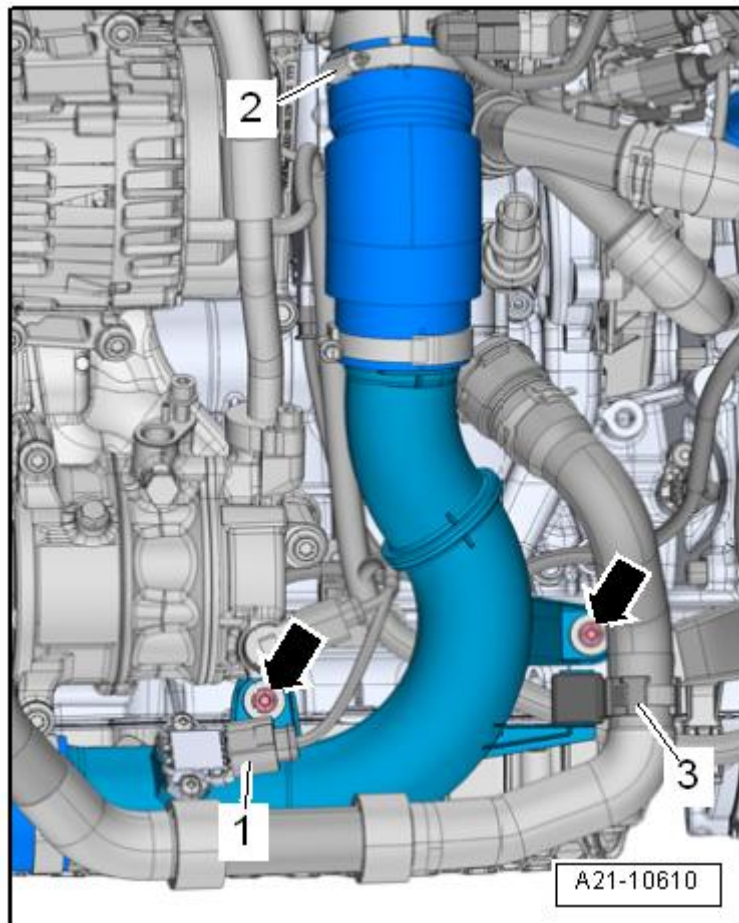

- Unplug the following electrical connectors:
 - 1 - from the combustion chamber injectors
 - 2 - From knock sensor 1 - G61-
 - 3 - Stage 3 oil pressure switch -F447-
For intake manifold flap valve -N316-, fuel pressure sender - G247-, intake manifold
 - 4 - flap potentiometer - G336-, coolant temperature sender - G62- and Hall sender - G40-

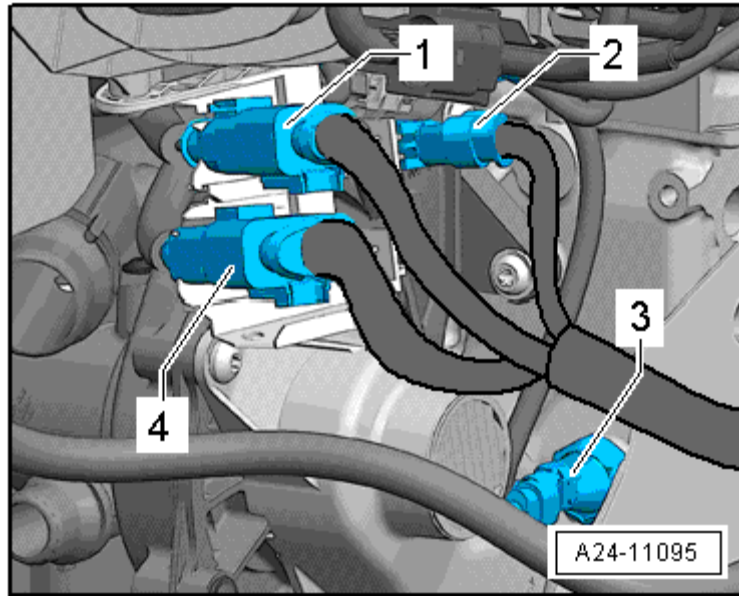

⚠ WARNING

Fuel system operates under high pressure. Always dissipate pressure in high-pressure section prior to opening fuel system.

Procedure : See → **Chapter „Reducing fuel pressure in high-pressure section“.**

- Disconnect fuel supply hose -1- from intake manifold.
- Pull electrical connectors - 3- out of retainer.
- Disconnect electrical connectors -4, 5 and 6-.
- Expose wiring harness from fuel rail.

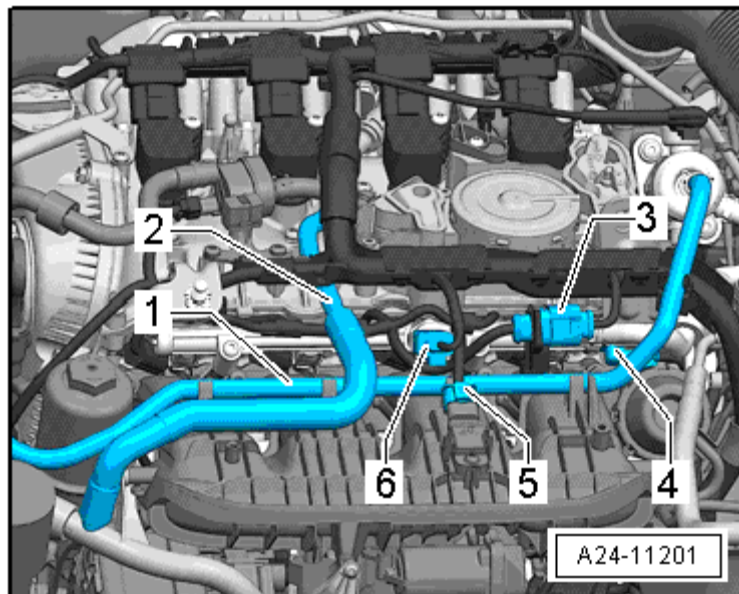

- Unplug electrical connector for intake manifold flap valve -N316-2-.
- Disconnect vacuum lines -arrows- from intake manifold flap valve -N316-2- and from air cleaner housing.

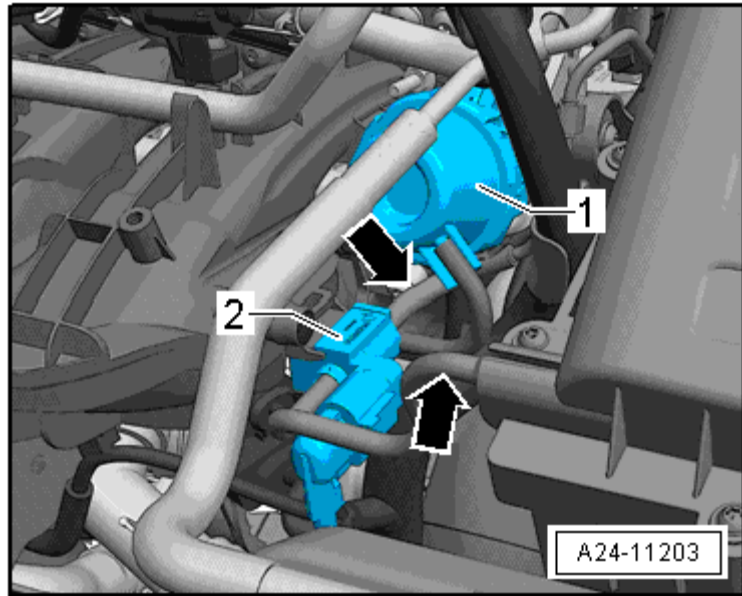

- Unscrew bolt -1- and push air pipe clear to left side.

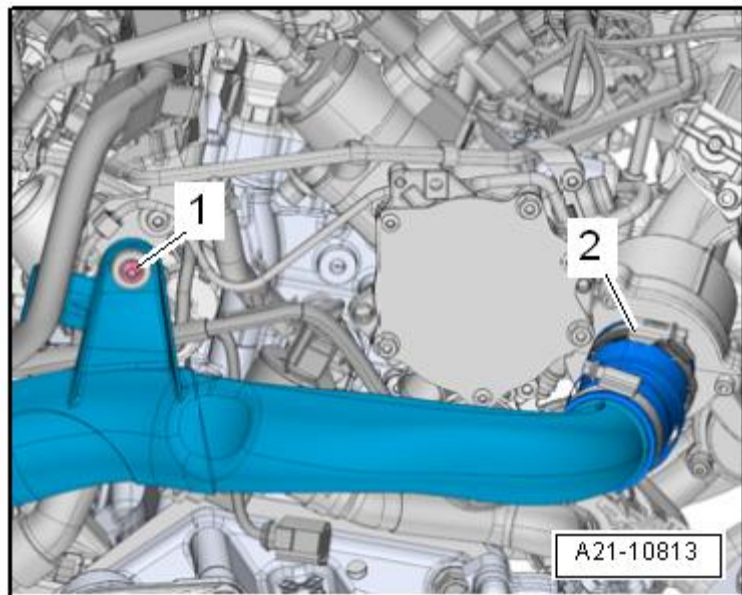

- Unscrew retaining clip - arrow- for high-pressure pipe.
- Open union nuts securing high-pressure pipe to high-pressure pump and fuel rail.
- Take out high-pressure pipe.



Note

- ◆ The fuel system must not be under pressure.
- ◆ Use a clean cloth to catch escaping fuel.
- ◆ Seal off open connections with clean caps. Make sure no dirt gets into the fuel system.

- Slightly loosen securing nut -top arrow- and completely unscrew bolt - bottom arrow-.

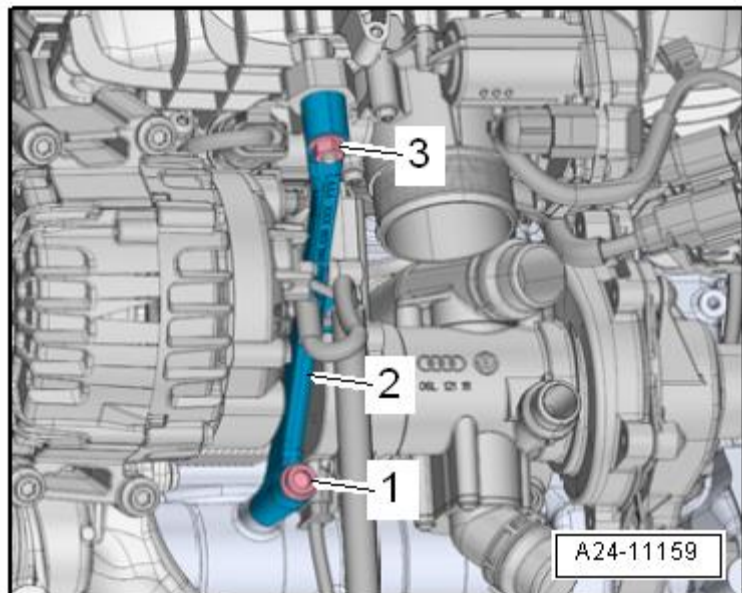
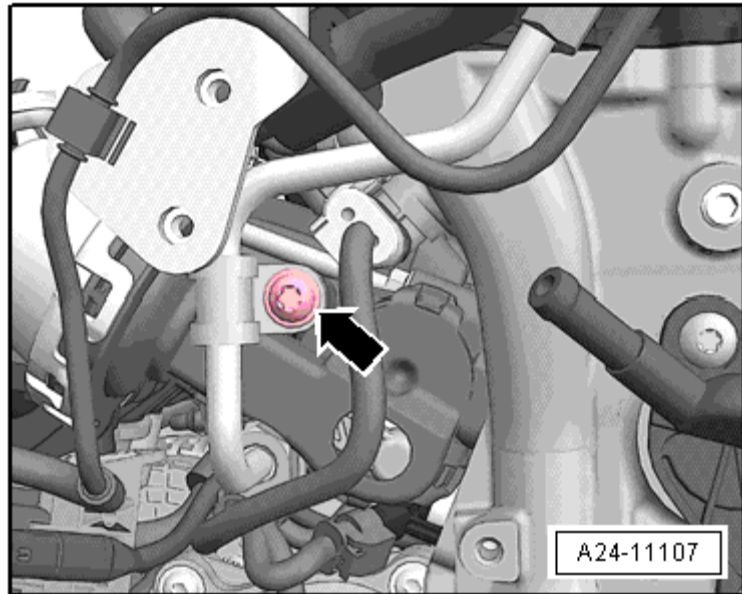

- Unplug electrical connector -1- from intake manifold flap potentiometer -G336-.
- Unscrew bolts from intake manifold using socket Torx T30 -T10347-.

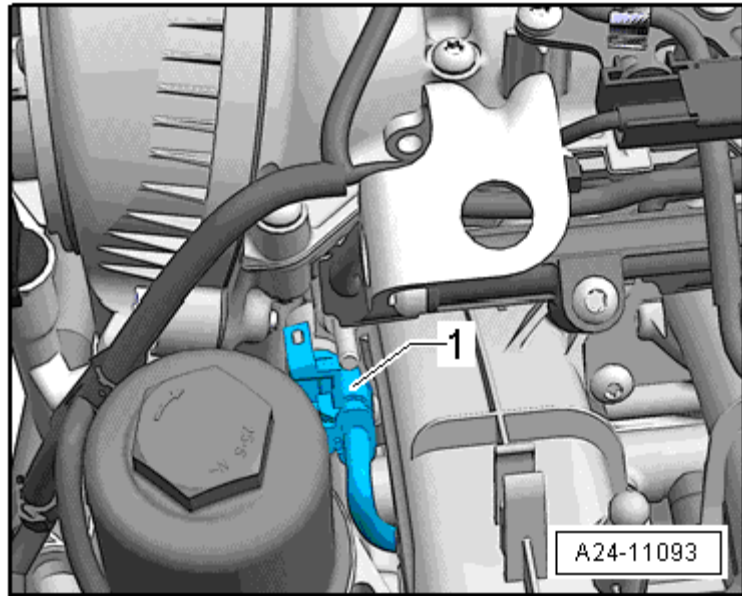

- Pull the intake manifold away a little from the cylinder head and unscrew the holder for the electrical connectors.



Note

Block off intake ports with a clean cloth.

Installation

- Renew both connecting pieces for high-pressure pipe.
- Tighten bolts of holder for the electrical connectors.
- Fit intake manifold onto studs (left and right) on cylinder head.
- The remaining installation steps are carried out in the reverse sequence.

Tightening torques

- ◆ → Chapter „Exploded view - fuel rail, direct injection“

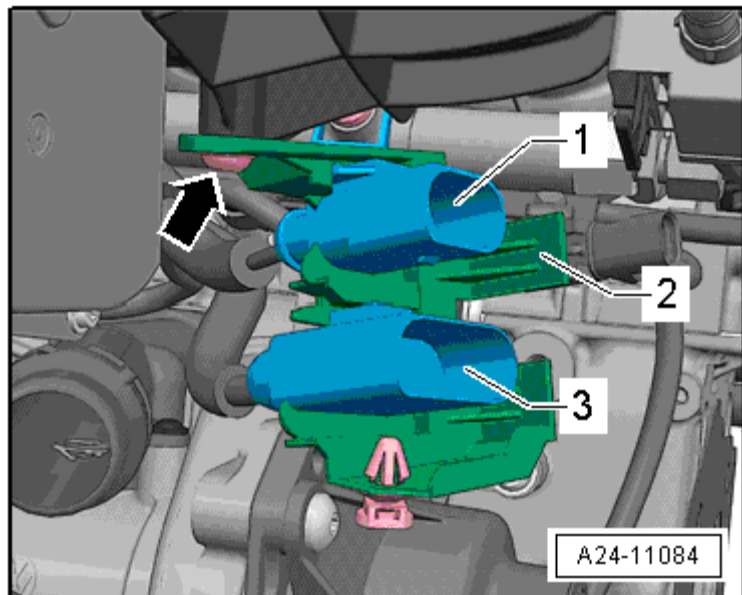

4.5 Removing and installing throttle valve module -GX3-

Throttle valve control unit -GX3- comprises:

- ◆ Throttle valve drive (electric power control) -G186-
- ◆ Throttle valve drive angle sender 1 (electric power control) -G187-
- ◆ Throttle valve drive angle sender 2 (electric power control) -G188-

Removing

- Remove engine cover → Chapter „Engine cover: Removing and installing“
- Remove bolts -1 and 3-
- Release fastener -arrow- and remove cover -2-.

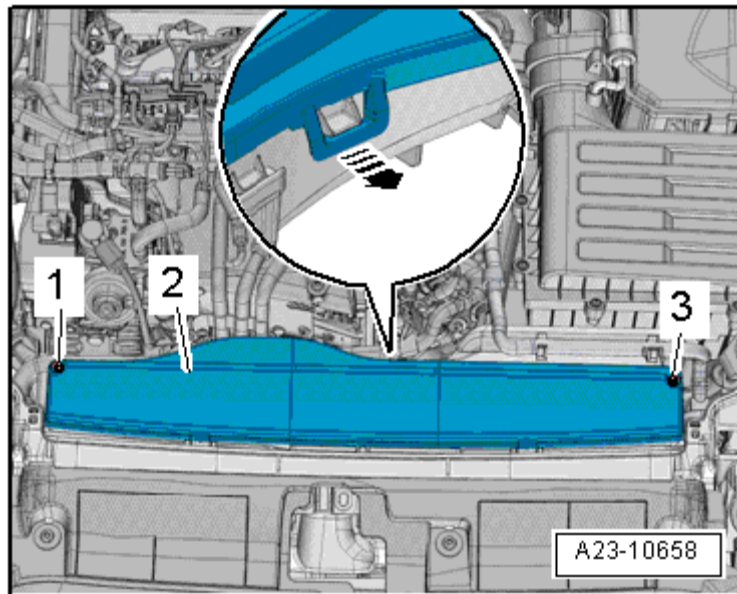

- Free coolant hose -2-.
- Release fastener -arrows- and detach air duct (top section) -1-.

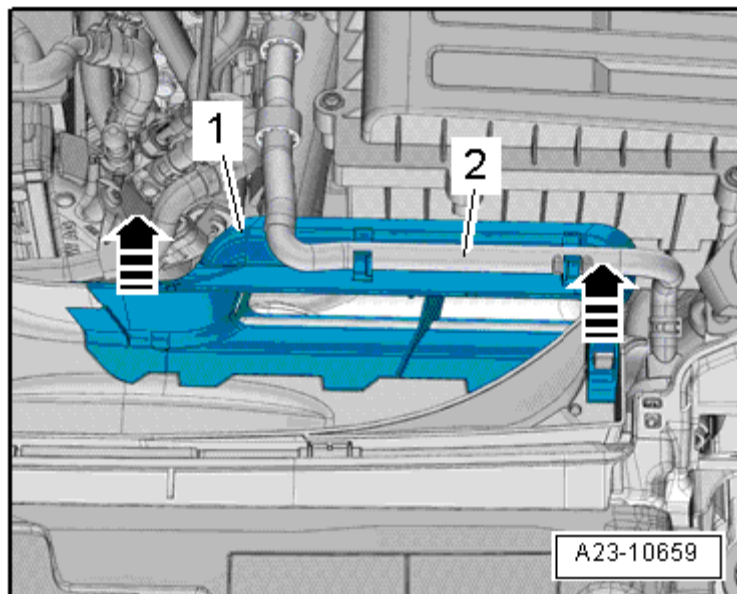

- Remove bolt -arrow- on both sides.
 - Unclip air duct (bottom section) -1- and detach.
 - Remove the sound proofing -1-
- Rep. gr.66.

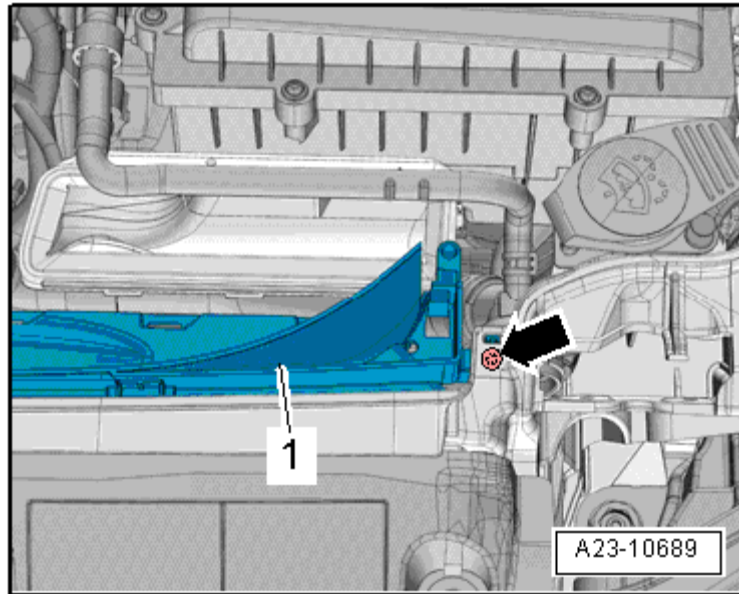

- Release hose clip -2- and detach air hose from charge air cooler.

 Note
Ignore -item 1-.

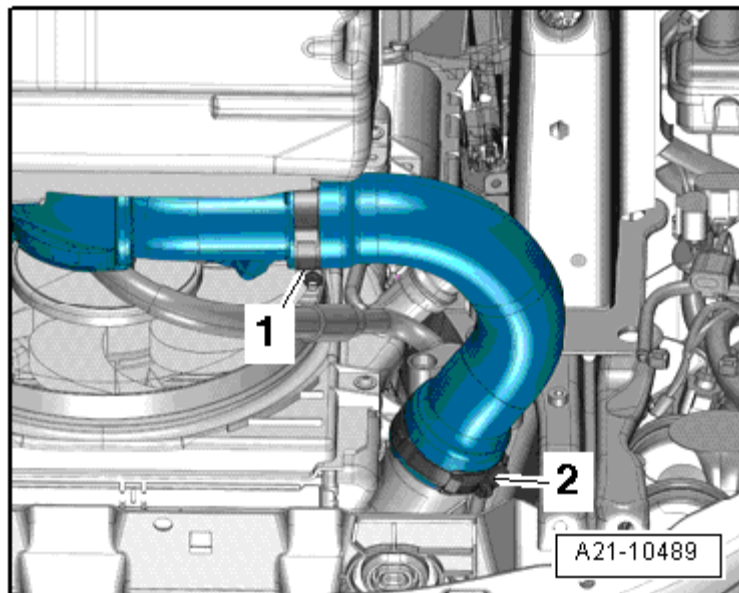

- Free coolant hose -3-.
- Unplug electrical connector -1- at charge pressure sender -G31-.
- Remove bolts -arrows-.
- Release hose clip -2- on air hose and pull air hose off throttle valve module -J338-.
- Remove the air hose by lowering it.

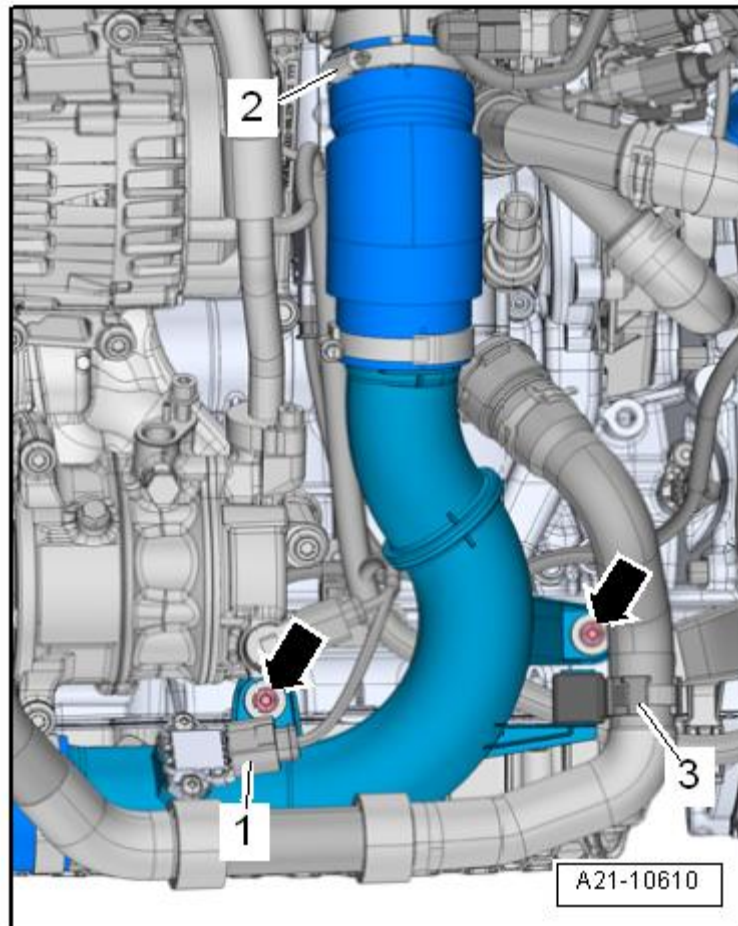

- Unplug electrical connector -1- from throttle valve module -J338-.
- Unscrew bolts -arrows- on throttle valve module -J338- from underneath and detach throttle valve module -J338-.

Installation

- Installation is carried out in the reverse order.
- Clean the sealing surfaces of the sealing ring.
- Renew seal.

Tightening torques

- → Chapter „Intake manifold: Assembly overview“

- After throttle valve module -J338- has been renewed, it must be re-adapted to engine control unit -J623-. Use → Vehicle diagnostic tester.

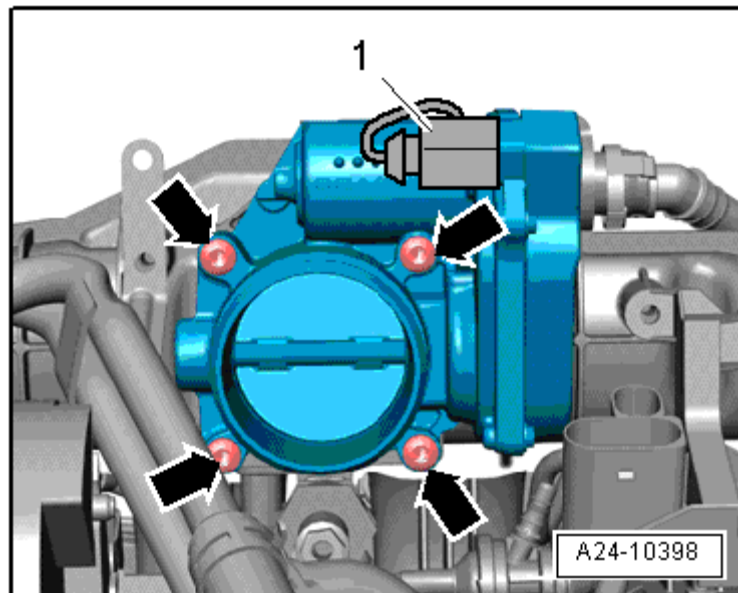

5 ALTERNATOR

5.1 Alternator without sliding bushes -exploded view-

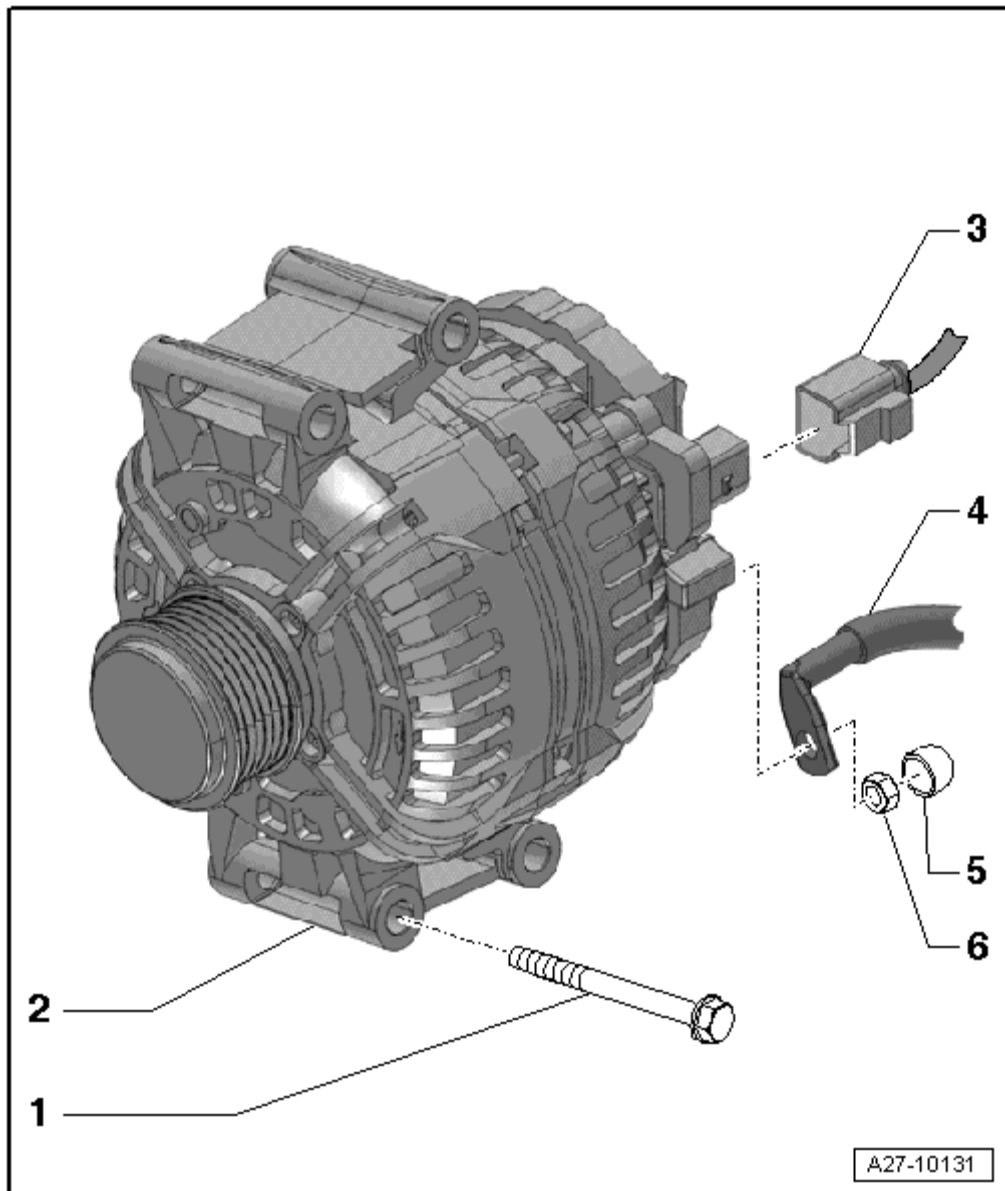

- 1 - Plug
 - 4x
 - 23 Nm
- 2 - Alternator:
 - Removing and installing → Chapter
 - repairs → Chapter
- 3 - Connector
- 4 - Terminal 30/B+
- 5 - Cap
- 6 - Nut
 - 20

Nm

5.2 Removing and installing the alternator, vehicles with 1.8 litre TSI engine

Special tools and workshop equipment required

- ◆ Torque wrenches -V.A.G 1331-

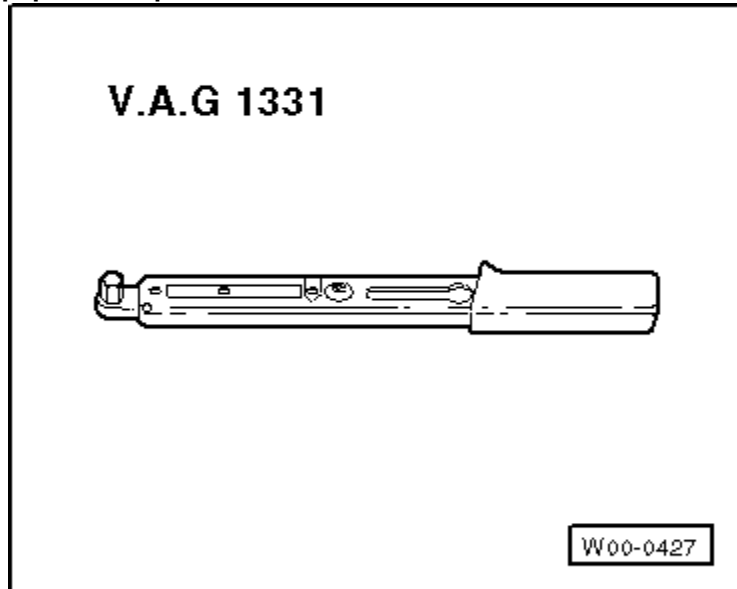

- ◆ Engine bung set -VAS 6122-
- Removal:
- With ignition switched off,
 - disconnect earth cable from battery -A- → **Chapter**.

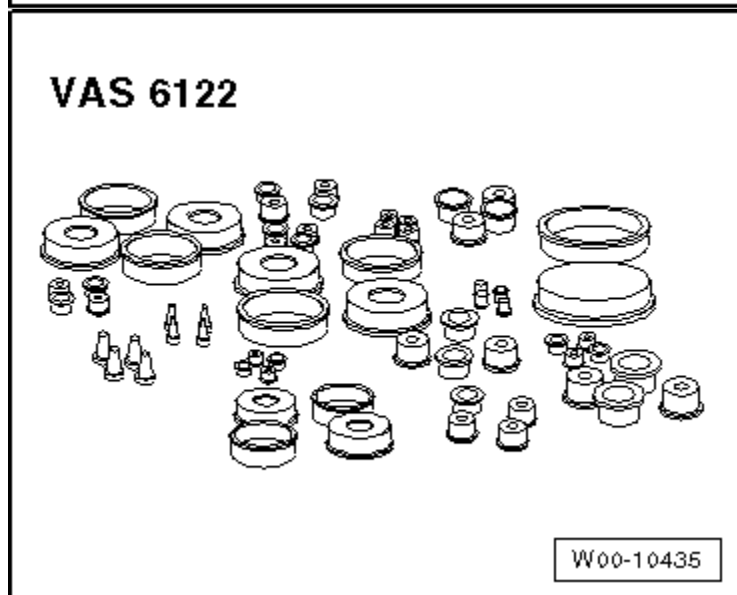

- Unscrew the attachment bolts -1- and -2- of the generator (alternator). Remove the lower engine noise insulation
- → Rep. gr.50.

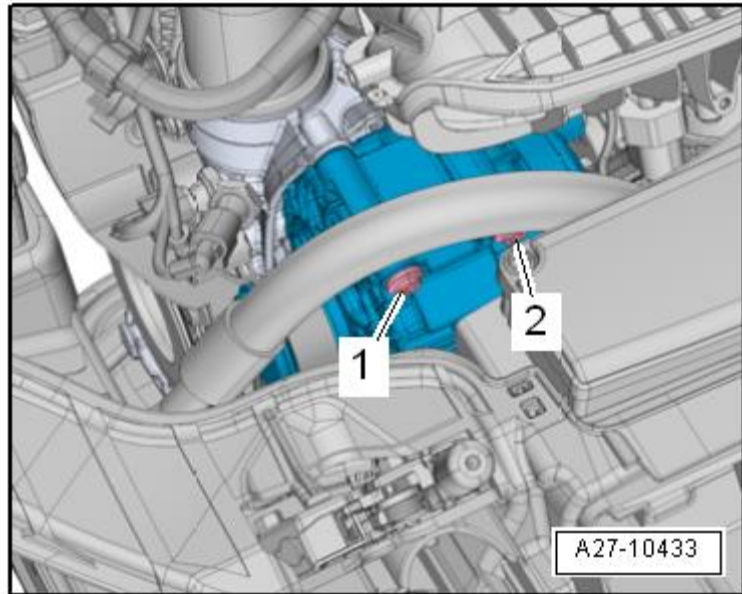

- Loosen hose clip -1-.

 Note
Ignore -item 2-.

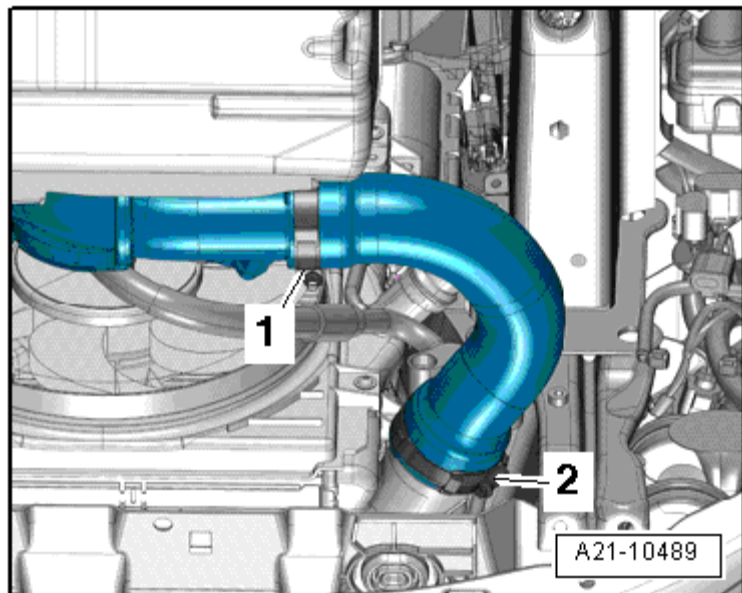

- Move clear coolant hose - 3-.
- Release hose clip -2-.
- Remove bolts -arrows-.
- Unplug connector -1-.
- Remove the air pipe.
- Seal open lines and connections with suitable plugs from engine bung set -VAS 6122-.
- Remove poly V-belt
-
- → Rep. gr.13.



Caution

Risk of damage to air conditioner compressor, refrigerant lines and refrigerant hoses:
Take care to avoid straining, kinking or bending refrigerant lines/hoses.

- Remove the mounting for the a.c. compressor
-
- → Rep. gr.87.
- Secure air conditioner compressor to lock carrier so that refrigerant lines are not under tension.

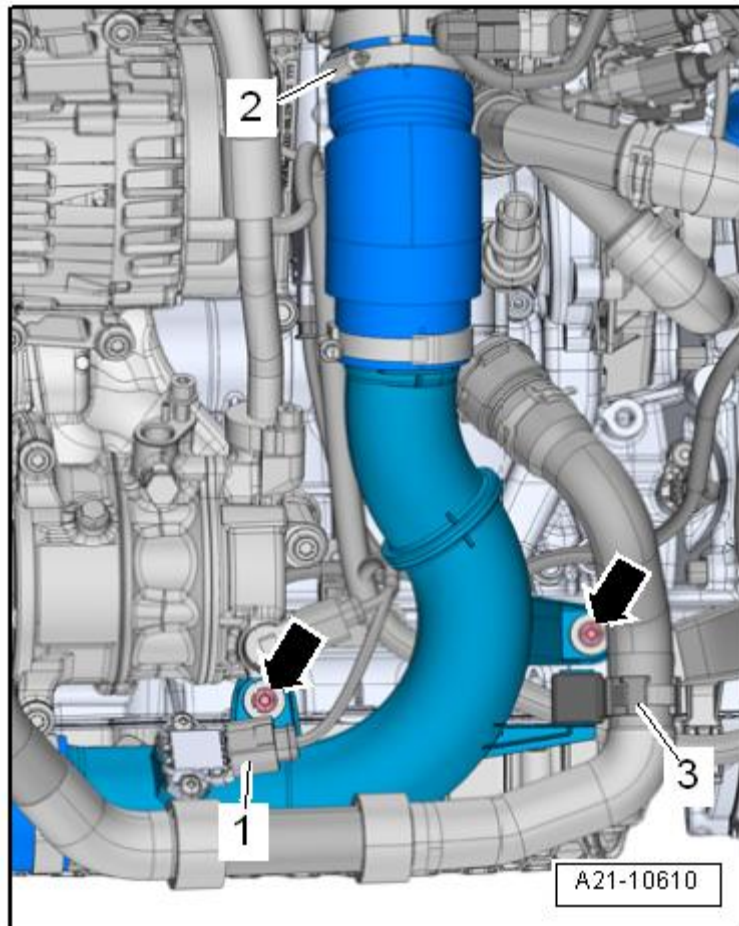

- Uncover the electrical wiring line -Arrow-.
- Unscrew bolts -5- and -6- and move alternator -C--4- towards front.
- Unplug connector -3-.
- Remove the cover -2-, by levering.
- Unscrew nut and remove terminal 30/B+ -1-.



Caution

Risk of damage to air conditioner compressor, refrigerant lines and refrigerant hoses:
Take care to avoid straining, kinking or bending refrigerant lines/hoses.

- Remove alternator -C--4- downwards to the right.

Installation

Carry out installation in the reverse sequence observing the following:

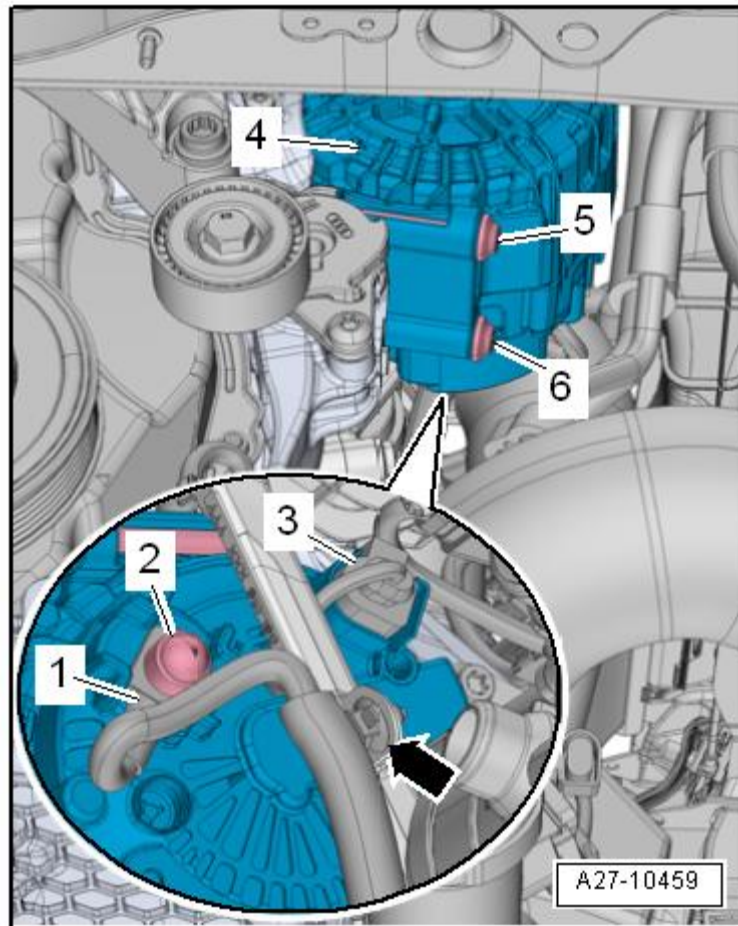

- Install the poly V-belt as depicted in the illustration:

- 1 - Vibration damper
- 2 - Tensioner for poly V-belt
- 3 - Alternator:
- 4 - Air conditioning compressor

- Connect battery -A- → Chapter.

- Always start engine and check belt running after completing work.

Tightening torques

- Chapter „Alternator without sliding bushes - exploded view“

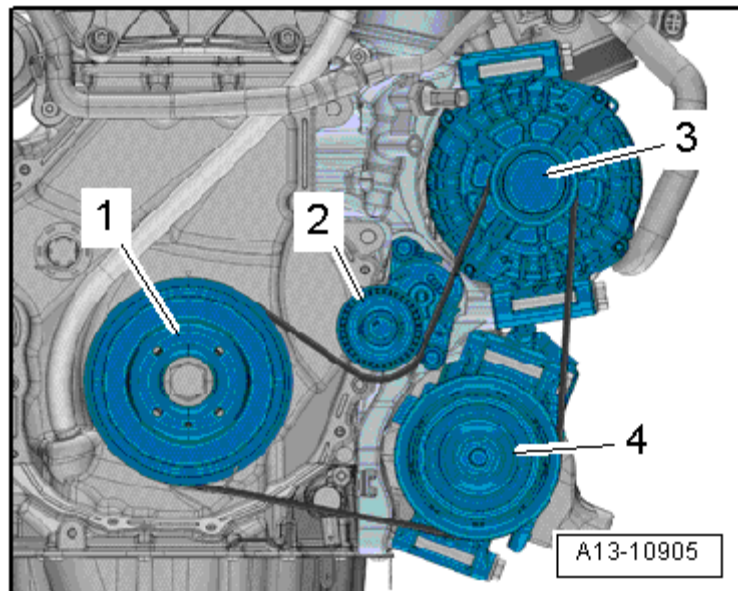

5.3 Tightening torques: Alternator:

Threaded connections		Specified torques
Cable B+ to alternator	M8	16 Nm
Air conduction tube to	Engine block	15 Nm
	Rear bracket	8 Nm
Fasten cables to alternator	M5	3.2 Nm
Voltage regulator to alternator	M4	2 Nm
Protector to alternator	M5	4.5 Nm
Alternator to compact support	M8	20 Nm
Tensioning element to compact support	M8	23 Nm
Compact support to engine block	M10:	40 Nm
Poly-V belt pulley with free-wheel to alternator	M10:	80 Nm
Poly-V belt pulley without free-wheel to alternator	M10:	65 Nm

6 DIFFERENTIAL

6.1 Assembly overview – Front differential lock

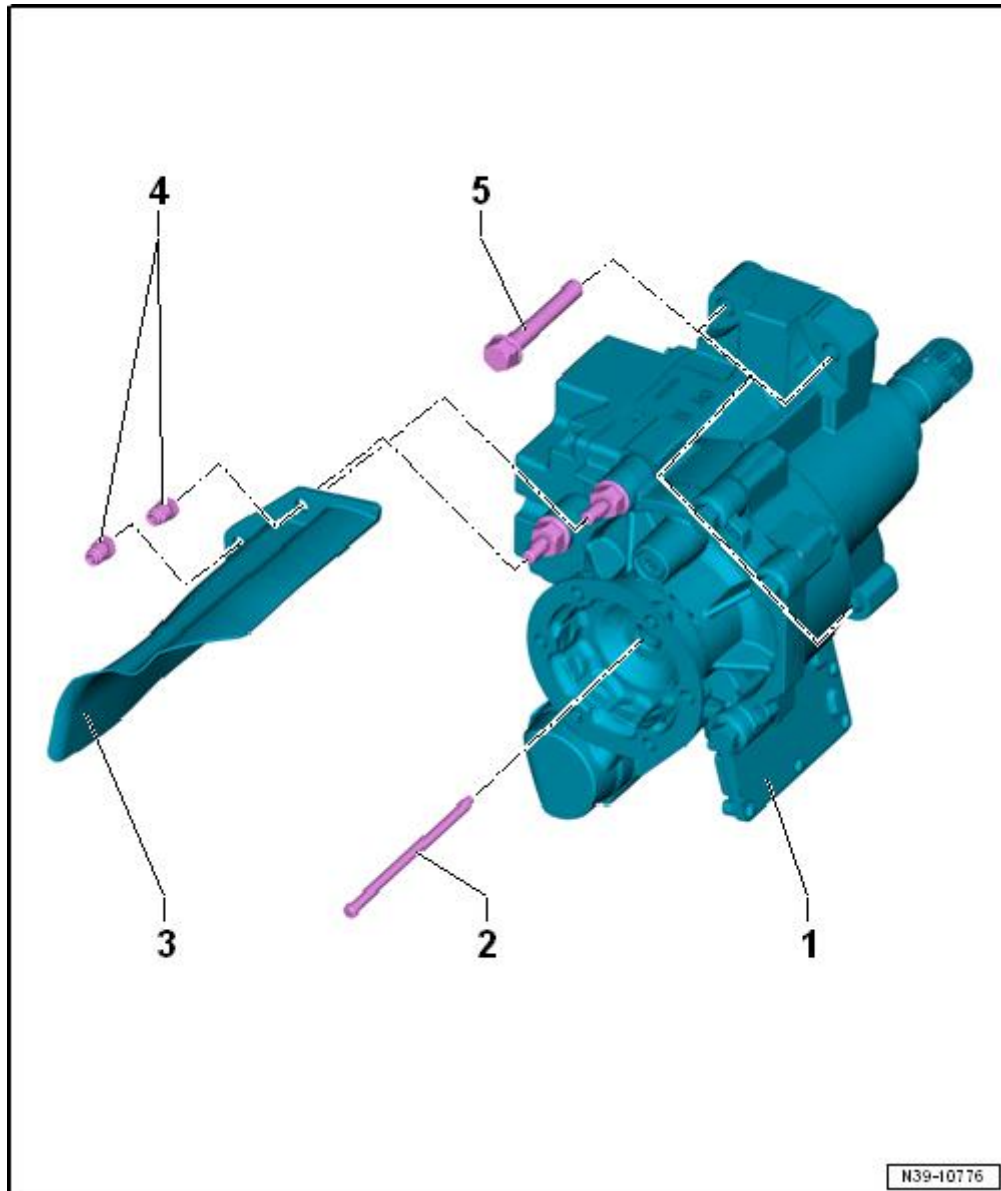

- 1 - Front differential lock
 - Removal → Chapter
 - Installing → Chapter
- 2 - Countersunk bolt
 - 30 Nm
- 3 - Heat shield
 - For drive shaft
- 4 - Nut
 - Qty. 2 or 3
 - Tightening torque

→ Rep. gr.40

5 - Plug

- 4x
- Replace after each removal
- 40 Nm + 90°

6.2 Removing front differential lock

Special tools and workshop equipment required

- ◆ Socket and key -T10107 A-
- ◆ Torque wrench -V.A.G 1331-

Removing:

- Raise vehicle. All 4 supports of lifting platform must be at same height.
- Shift selector lever into position »P«.



Note

Do not place the vehicle on the ground once the centre bolt has been removed.

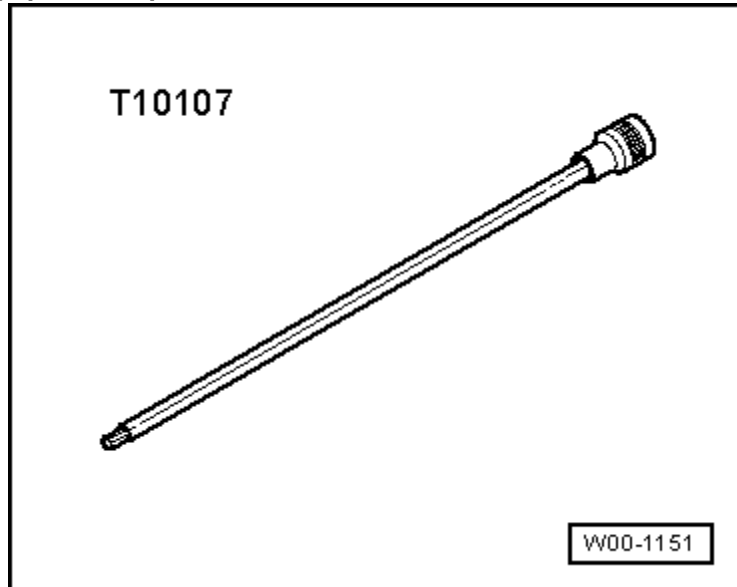

- Step on the brake pedal while a 2nd mechanic loosens the right drive shaft bolt -arrow-.
 - Remove noise insulation
- Rep. gr.66.

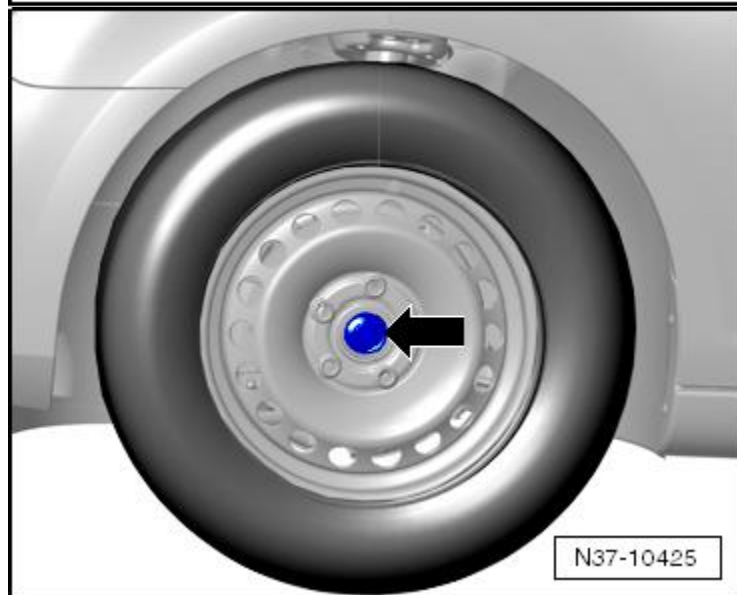

- Remove drive shaft heat shield, if present, from bevel box (-arrows-)

→ Rep. gr.40.

- Remove right-hand drive shaft

→ Rep. gr.40.



Caution

Risk of damage to decoupling element.

→ Rep. gr.26.

- Remove front exhaust pipe from engine and tie it up

→ Rep. gr.26.

- Pull connector -arrow- off transverse lock-up control unit -J647-.

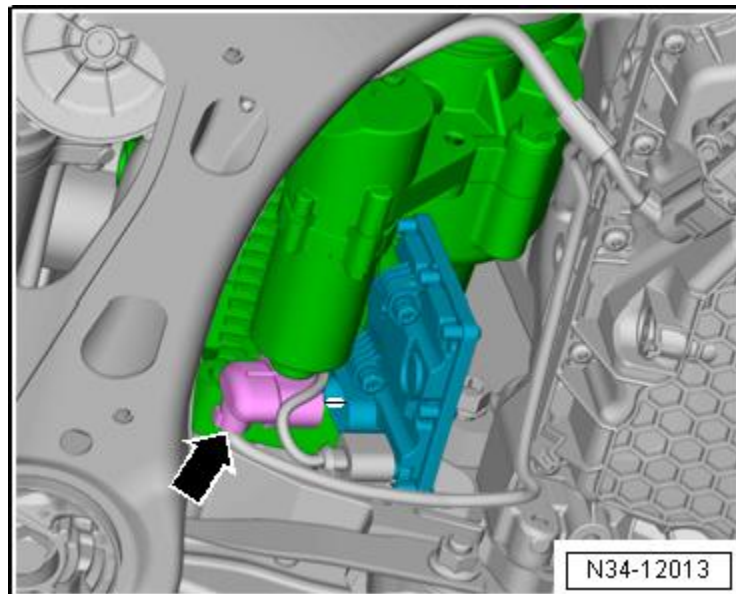
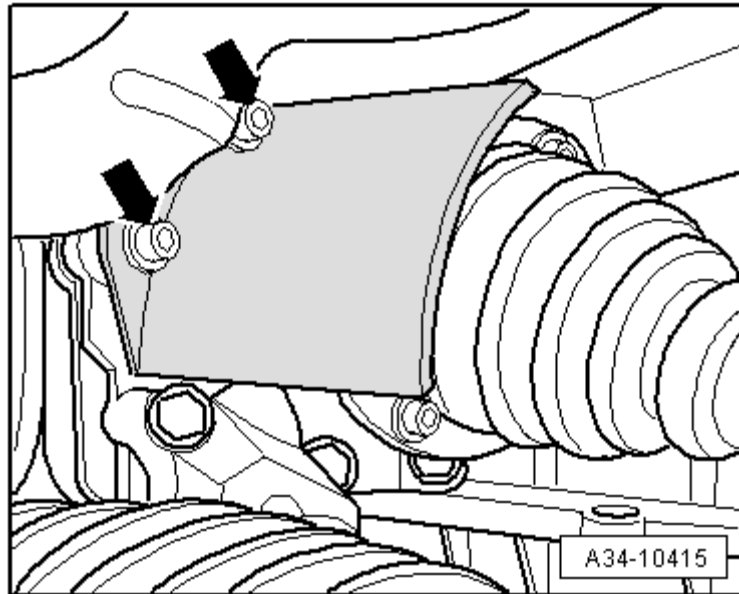

- Detach connector -1- from oil level and oil temperature sender -G266-.

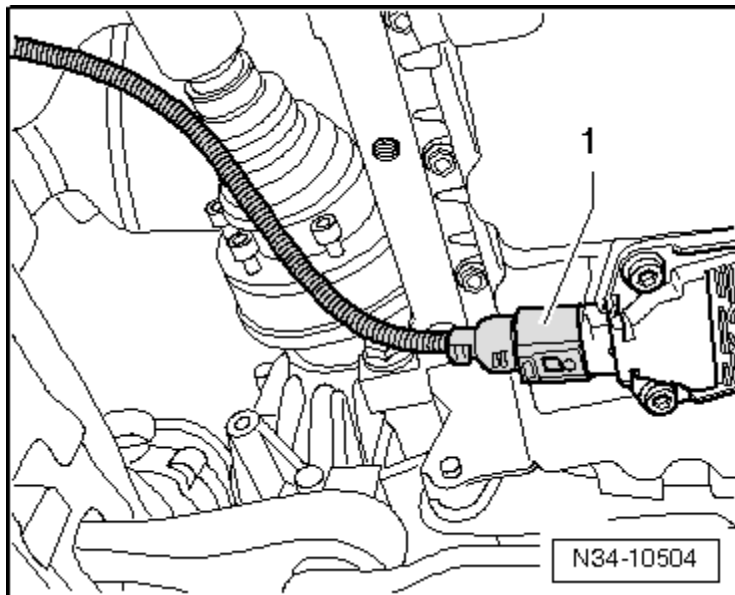

- Unscrew pendulum support bolts -1- from gearbox.

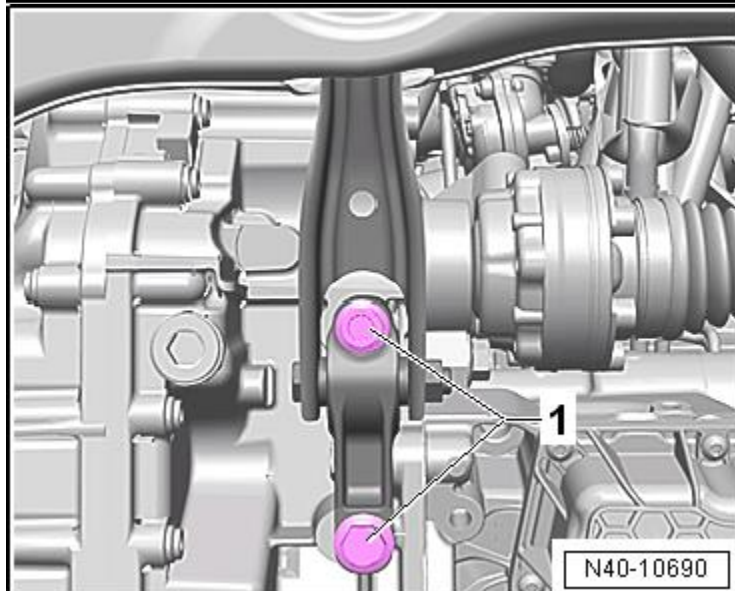

- Remove securing bolt for right flange shaft with socket by screwing 2 bolts into flange and counterholding flange shaft with a lever.

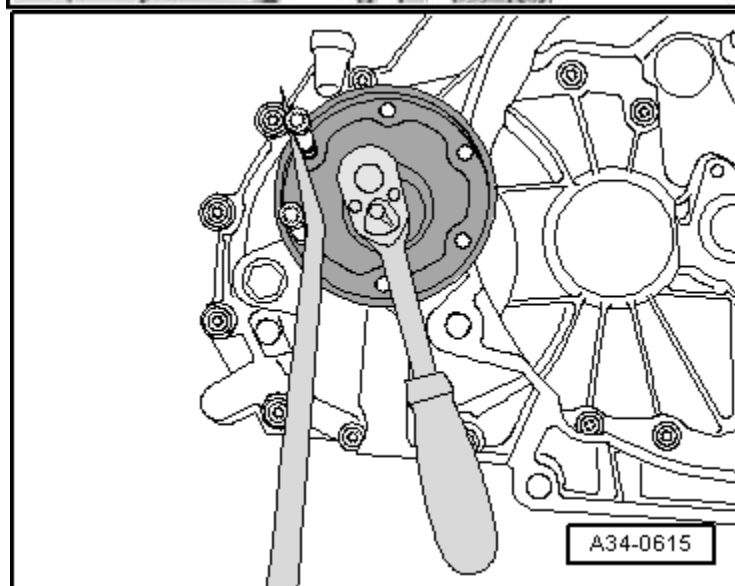

- Unscrew upper securing bolts -arrows- for securing front differential lock to gearbox.

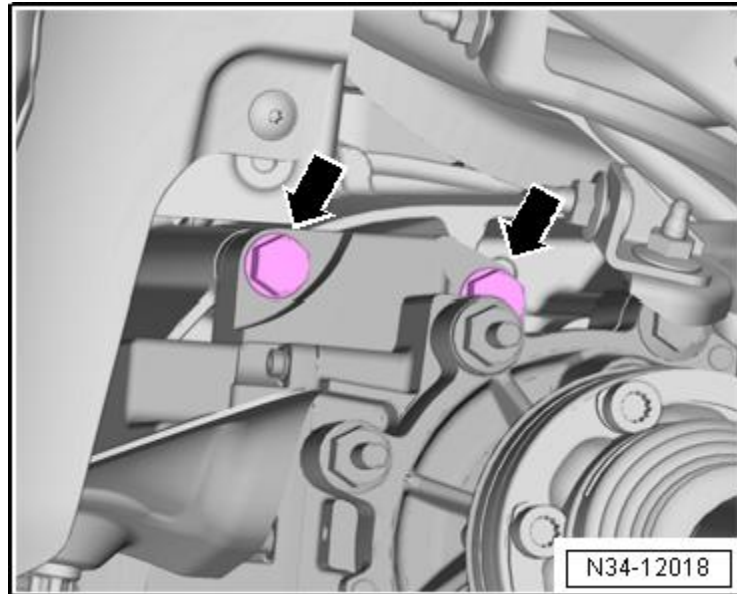

- Unscrew lower securing bolts -arrows- for securing front differential lock to gearbox.
- Have a second mechanic push engine/gearbox assembly towards front end slightly.
- Carefully press front differential lock off gearbox and remove it.

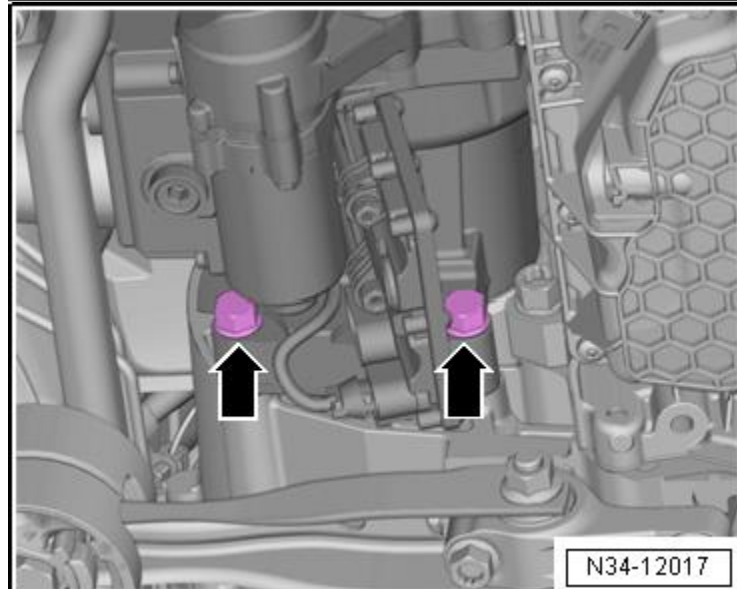

- Protect connector -arrow- from being damaged.

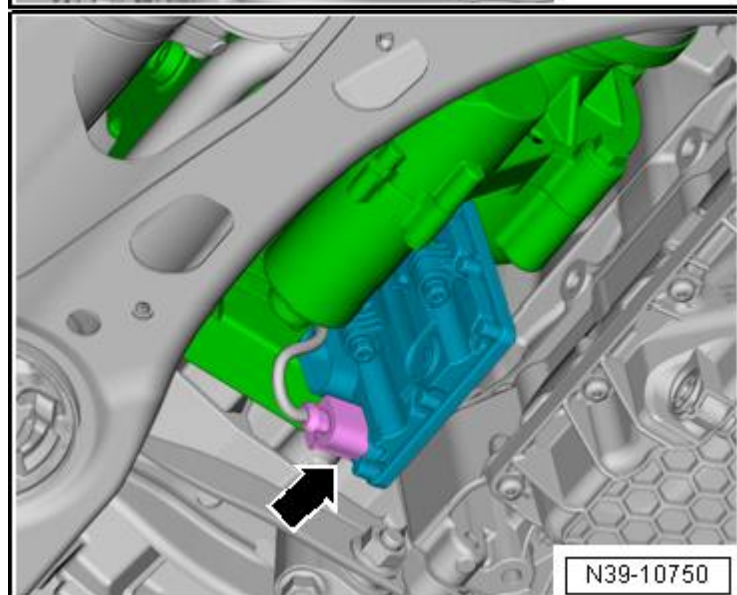

6.3 Installing front differential lock

Installation is carried out in the reverse sequence; note the following:

- Have a second mechanic push engine/gearbox assembly towards front end.
Push front differential lock completely onto gearbox.
- When doing this, join flange shaft/front differential lock splines and differential centrally. Turn flange shaft if necessary.
- If splines are correctly positioned and shafts are centred, then the front differential lock will slide to stop against gearbox.
- All cable ties which were opened or cut during removal must be renewed at the same points.



Note

Do not use securing bolts to pull the front differential lock against the gearbox. Otherwise the front differential lock will cant and the bolt holes may break off.

- Screw in lower securing bolts -arrows- for front differential lock and tighten them.
Tightening torque: → **Item**

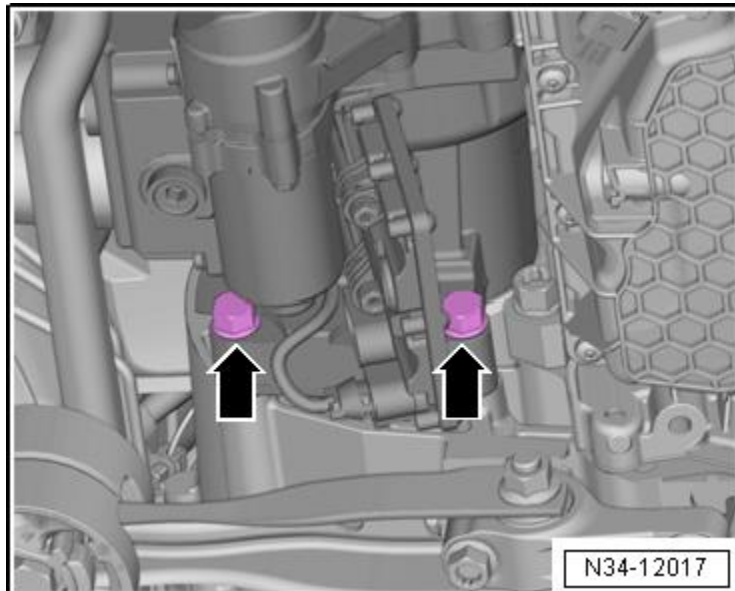

- Screw in upper securing bolts -arrows- for front differential lock and tighten them. Tightening torque: → **Item**

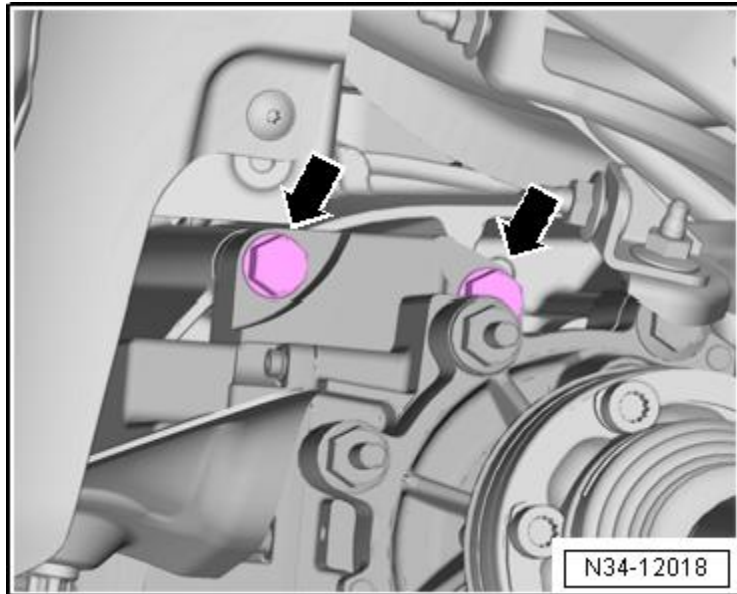

- Bolt on flange shaft. Tightening torque: → **Item**

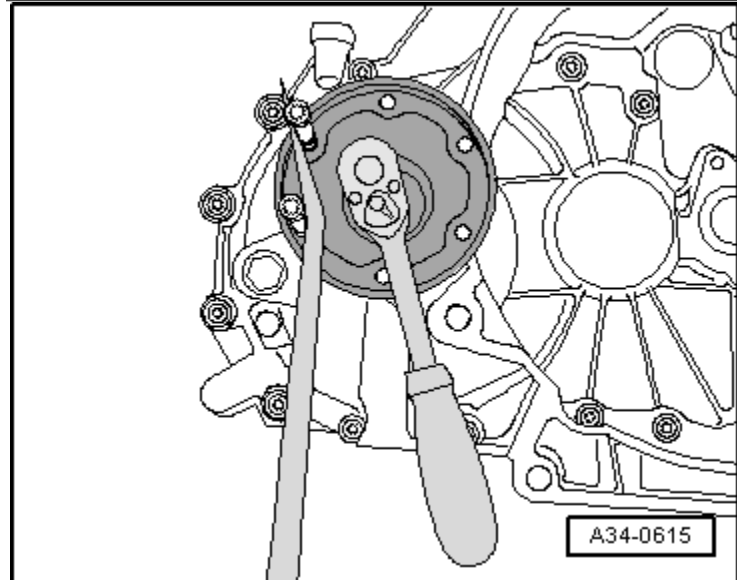

- Install new bolts-1- to secure the pendulum support → **Rep. gr.10**

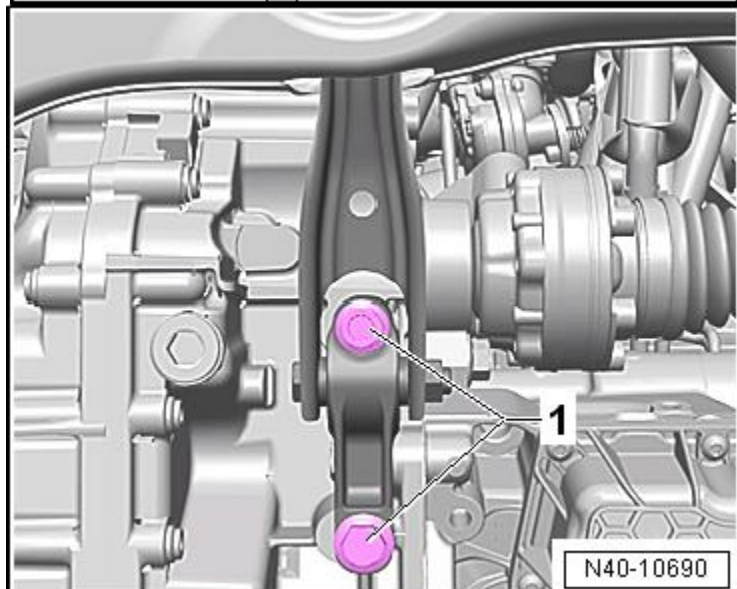

- Connect connector -arrow- to transverse lock-up control unit -J647-.

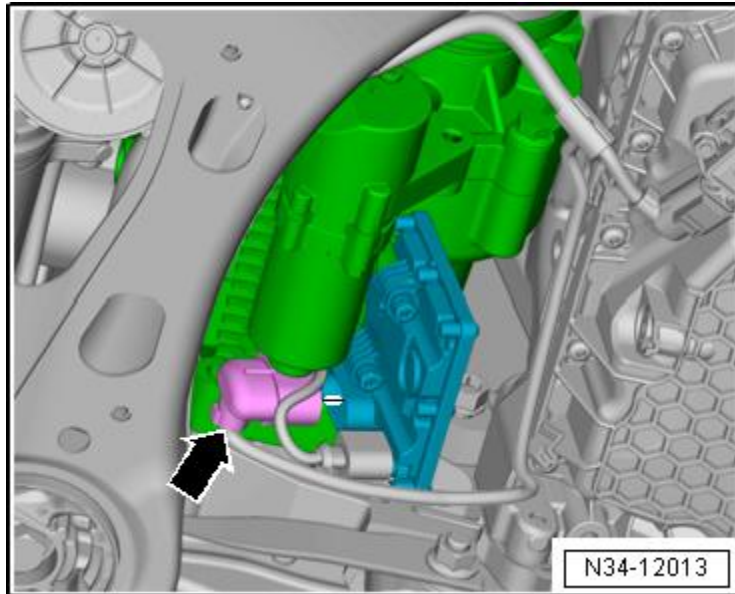

- Install right-hand drive shaft
 - Rep. gr.40.
- If fitted, install drive shaft heat shield -arrows-
 - Rep. gr.40.
- Top up gear oil in front differential lock
 - Chapter.
- Assemble exhaust system
 - Rep. gr.26.
- Install noise insulation
 - Rep. gr.66.
- After installation of front differential lock, perform **Basic settings** using → **vehicle diagnostic tester** in **Guided functions** mode.

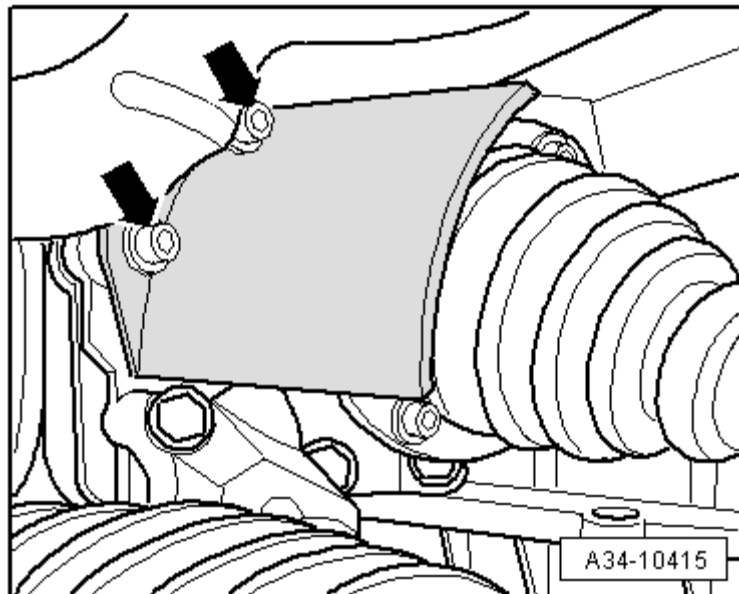

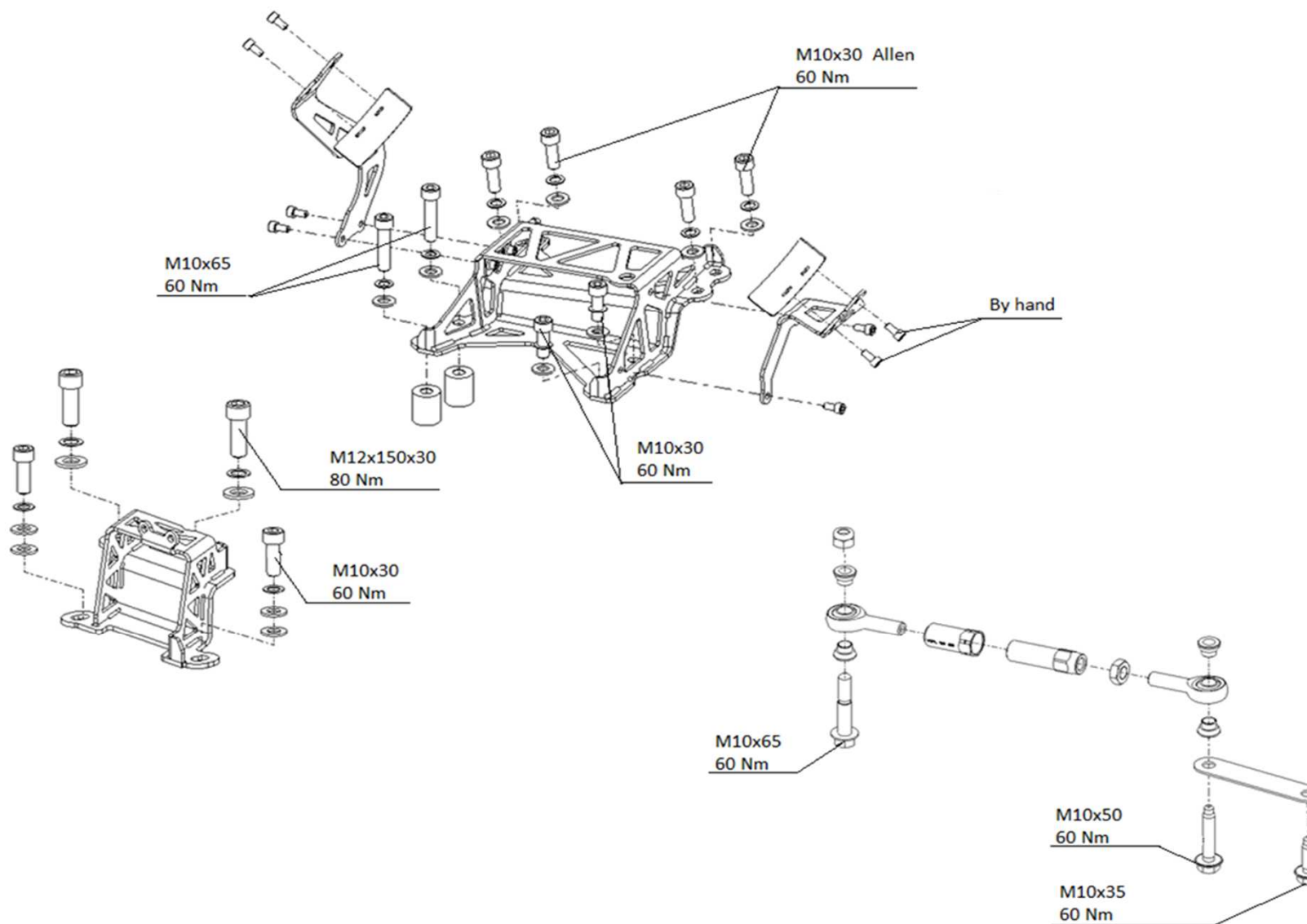
Unterlagen
References

© SEAT SPORT behält sich alle Rechte vor. Das gilt insbesondere fuer Erfindungsrechte, Know-how, Urheberrechte und Namensrechte, sowie fuer das Recht, dieses als gewerbliche Schutzrechte anzumelden. Jede Verfuugungsbefugnis ist. Están reservados todos los derechos de disposición, en especial a copiar o distribuir.

© All rights remain with SEAT SPORT. This applies especially to rights of invention, know-how, copyrights and rights to name as well as for the right to patent these as commercial protective rights. All rights of disposition, particularly for copying or distributing, reserved.

Bemerkungen / Notes

Nr. No.	Datum Date	NAME	Genehmigt Appr.	Beschreibung der Aenderung und Aenderungsterminschlüssel Revision record and change date code	Typ-Pruef-Dok. und Typ-Pruef-Nr./ Type-appr.- doc and type approval number	CAD-System und Verwaltungssystem - Schlüssel CAD-system and administration code	Sicherheits-Dok Safety-doc.
	23/04/14	OSN	ok	Edición		ProE	Konst.Verantw./Design resp.
					Benennung	Engine Brackets	Name A. Almirall
					Title	Engine Brackets	Abt./Dept. O.T.
					EA-Nr. / eng. proj. no.	V3FL	Tel.
							Gez./Drawn ProE
							Blatt/sheet 001
							Format/D.size A3

Unterlagen
References

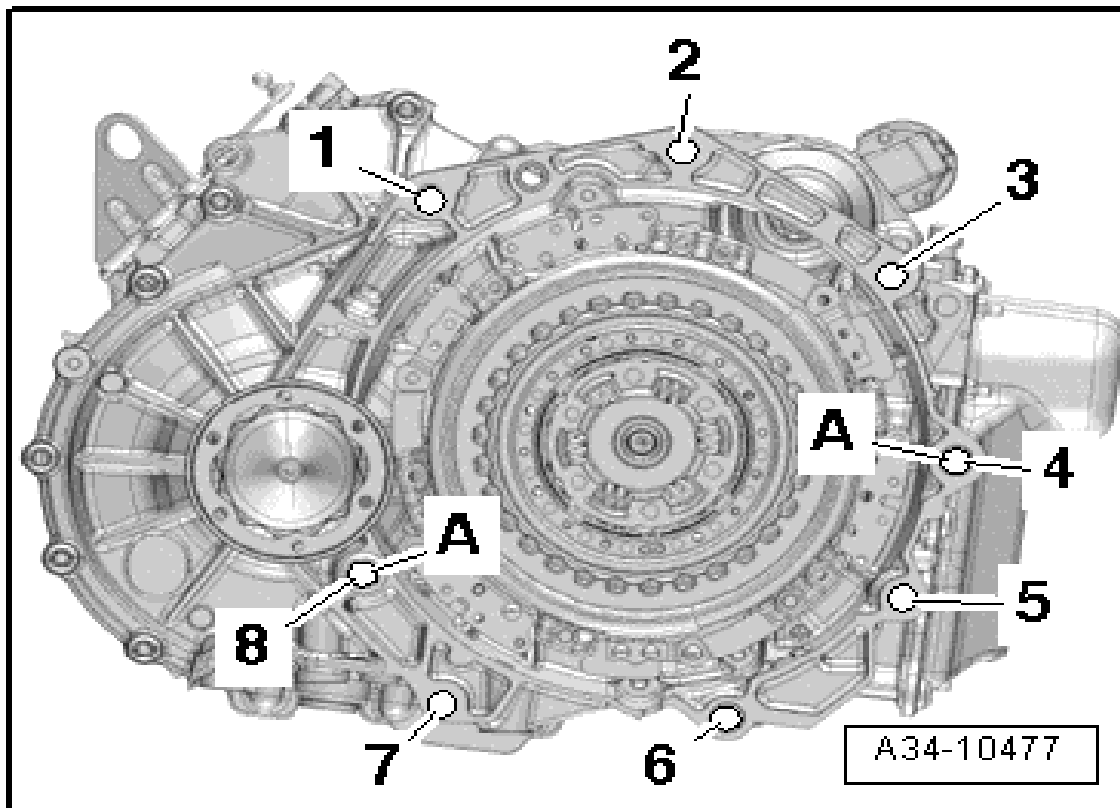

Pos	Thingten	Info
1, 2, 3*, 4	80 Nm	M12x55
5, 6, 7	40 Nm	M10x50
8	80 Nm	M12x65
A	Centering	
3*	Acces rear starter	

© SEAT SPORT behält sich alle Rechte vor. Das gilt insbesondere fuer Erfindungsrechte, Know-how, Urheberrechte und Namensrechte, sowie fuer das Recht, dieses als gewerbliche Schutzrechte anzumelden. Jede Verfuugungsbefugnis ist. Están reservados todos los derechos de disposición, en especial a copiar o distribuir. © All rights remain with SEAT SPORT. This applies especially to rights of invention, know-how, copyrights and rights to name as well as for the right to patent these as commercial protective rights. All rights of disposition, particularly for copying or distributing, reserved.	Nr. No.	Datum Date	NAME	Genehmigt Appr.	Beschreibung der Aenderung und Aenderungsterminschiussel Revision record and change date code	Typ-Pruef-Dok. und Typ-Pruef-Nr./ Type-appr.-doc and type approval number	CAD-System und Verwaltungssystem - Schluessel CAD-system and administration code	Sicherheits-Dok Safety-doc.
		23/04/14	OSN	ok	Edición	Benennung Gear Box	ProE	Konst.Verantw./Design resp. Name A. Almirall
Bemerkungen / Notes						Title Gear Box		Abt./Dept. O.T.
						EA-Nr. / eng. proj. no.	V3FL	Tel. Gez./Drawn ProE
							Blatt/sheet 002	Format/D.size A3

Unterlagen
References

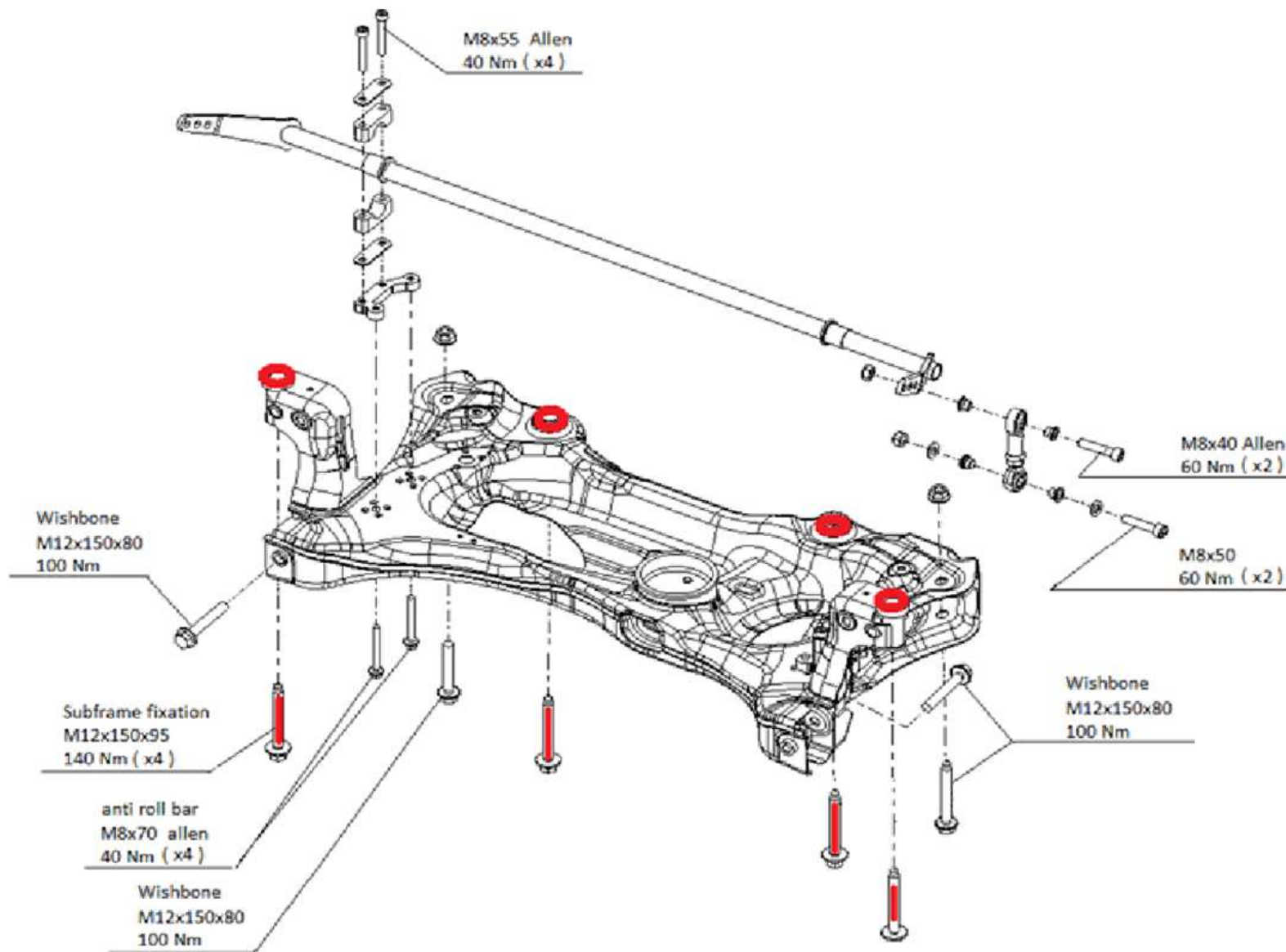

© SEAT SPORT behält sich alle Rechte vor. Das gilt insbesondere fuer Erfindungsrechte, Know-how, Urheberrechte und Namensrechte, sowie fuer das Recht, dieses als gewerbliche Schutzrechte anzumelden. Jede Verfuugungsbezugnis incl. Están reservados todos los derechos de disposición, en especial a copiar o distribuir.

© All rights remain with SEAT SPORT. This applies especially to rights of invention, know-how, copyrights and rights to name as well as for the right to patent these as commercial protective rights. All rights of disposition, particularly for copying or distributing, reserved.

Nr. No.	Datum Date	NAME	Genehmigt Appr.	Beschreibung der Aenderung und Aenderungsterminschiuesel Revision record and change date code	Typ-Pruef-Dok. und Typ-Pruef-Nr./ Type-appr.-doc and type approval number	CAD-System und Verwaltungssystem - Schluessel CAD-system and administration code	Sicherheits-Dok Safety-doc.
	23/04/14	OSN	ok	Edición	Benennung	ProE	Konst.Verantw./Design resp.
					Front Subframe & ARB		Name A. Almirall
					Title		Abt./Dept. O.T.
					EA-Nr. / eng. proj. no.		Tel.
					V3FL		Gez./Drawn ProE
							Blatt/sheet 003
							Format/D.size A3

Bemerkungen / Notes

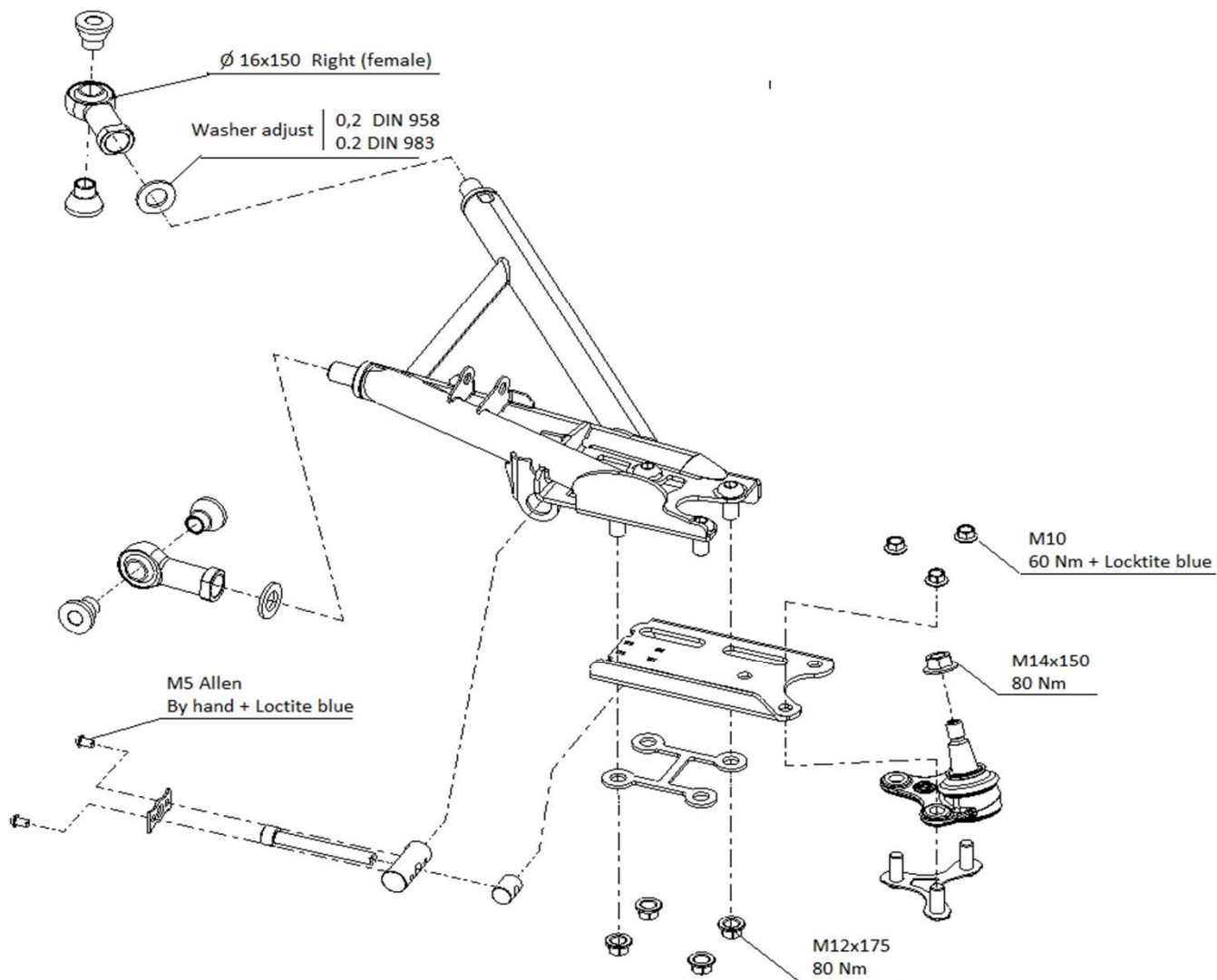
Unterlagen
References

© SEAT SPORT behält sich alle Rechte vor. Das gilt insbesondere fuer Erfindungsrechte, Know-how, Urheberrechte und Namensrechte, sowie fuer das Recht, dieses als gewerbliche Schutzrechte anzumelden. Jede Verfuugungsbefugnis ist. Están reservados todos los derechos de disposición, en especial a copiar o distribuir.

© All rights remain with SEAT SPORT. This applies especially to rights of invention, know-how, copyrights and rights to name as well as for the right to patent these as commercial protective rights. All rights of disposition, particularly for copying or distributing, reserved.

Bemerkungen / Notes

Nr. No.	Datum Date	NAME	Genehmigt Appr.	Beschreibung der Aenderung und Aenderungsterminschiussel Revision record and change date code	Typ-Pruef-Dok. und Typ-Pruef-Nr./ Type-appr.-doc and type approval number	CAD-System und Verwaltungssystem - Schluessel CAD-system and administration code	Sicherheits-Dok Safety-doc.
	23/04/14	OSN	ok	Edición		ProE	Konst.Verantw./Design resp.
					Benennung	Front Wishbone	Name A. Almirall
					Title	Front Axle	Abt./Dept. O.T.
					EA-Nr. / eng. proj. no.	V3FL	Gez./Drawn ProE
							Blatt/sheet 004
							Format/D.size A3

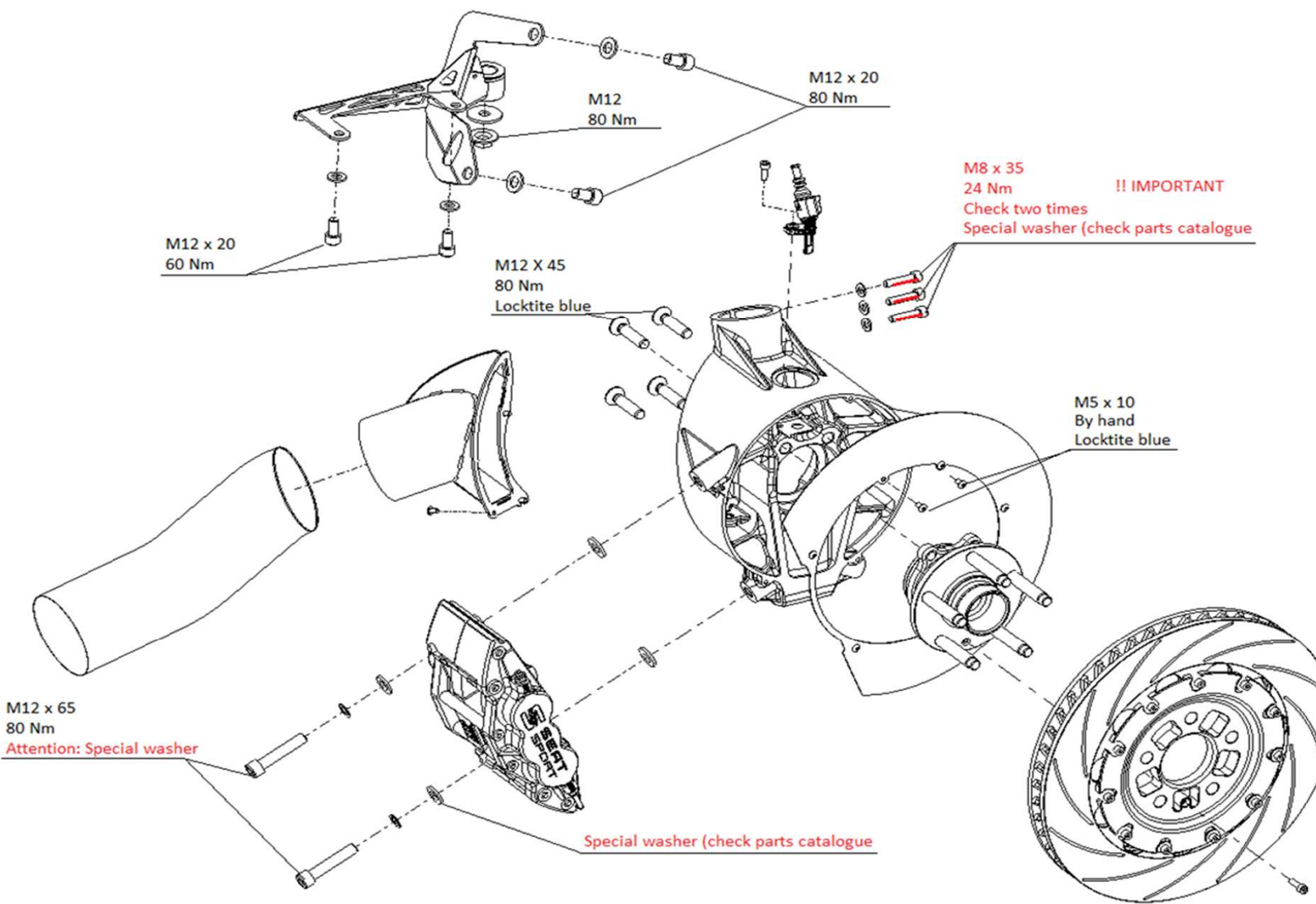
Unterlagen
References

© SEAT SPORT behält sich alle Rechte vor. Das gilt insbesondere fuer Erfindungsrechte, Know-how, Urheberrechte und Namensrechte, sowie fuer das Recht, dieses als gewerbliche Schutzrechte anzumelden. Jede Veruegungsbefugnis ist reserviert.
 Están reservados todos los derechos de disposición, en especial a copiar o distribuir.
 © All rights remain with SEAT SPORT. This applies especially to rights of invention, know-how, copyrights and rights to name as well as for the right to patent these as commercial protective rights.
 All rights of disposition, particularly for copying or distributing, reserved.

Bemerkungen / Notes

Nr. No.	Datum Date	NAME	Genehmigt Appr.	Beschreibung der Aenderung und Aenderungsterminschiussel Revision record and change date code	Typ-Pruef-Dok. und Typ-Pruef-Nr./ Type-appr.-doc and type approval number	CAD-System und Verwaltungssystem - Schluessel CAD-system and administration code	Sicherheits-Dok Safety-doc.
	23/04/14	OSN	ok	Edición		ProE	Konst.Verantw./Design resp.
					Benennung	Front Upright	Name A. Almirall
					Title	Front Axle	Abt./Dept. O.T.
					EA-Nr. / eng. proj. no.	V3FL	Tel.
							Gez./Drawn ProE
							Blatt/sheet 005
							Format/D.size A3

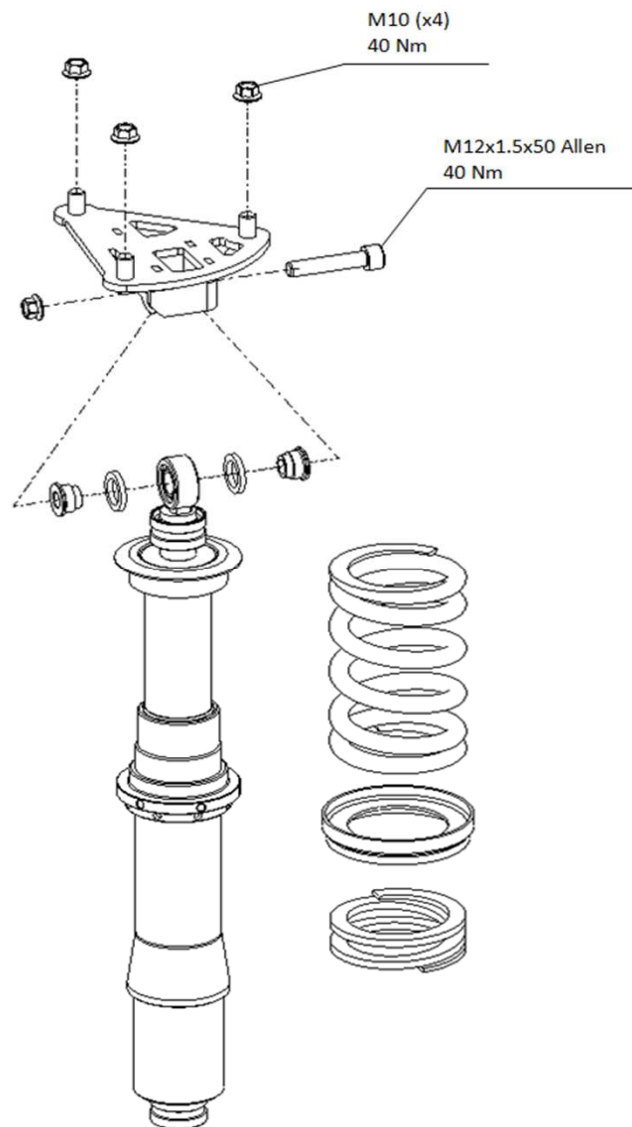
Unterlagen
References

© SEAT SPORT behält sich alle Rechte vor. Das gilt insbesondere fuer Erfindungsrechte, Know-how, Urheberrechte und Namensrechte, sowie fuer das Recht, dieses als gewerbliche Schutzrechte anzumelden. Jede Verfuugungsbefugnis ist. Están reservados todos los derechos de disposición, en especial a copiar o distribuir.

© All rights remain with SEAT SPORT. This applies especially to rights of invention, know-how, copyrights and rights to name as well as for the right to patent these as commercial protective rights. All rights of disposition, particularly for copying or distributing, reserved.

Bemerkungen / Notes

Nr. No.	Datum Date	NAME	Genehmigt Appr.	Beschreibung der Aenderung und Aenderungsterminschiussel Revision record and change date code	Typ-Pruef-Dok. und Typ-Pruef-Nr./ Type-appr.- doc and type approval number	CAD-System und Verwaltungssystem - Schluessel CAD-system and administration code	Sicherheits-Dok Safety-doc.
	23/04/14	OSN	ok	Edición		ProE	Konst.Verantw./Design resp.
					Benennung	Front Shock Absorber	Name A. Almirall
					Title	Front Axle	Abt./Dept. O.T.
					EA-Nr. / eng. proj. no.	V3FL	Tel.
							Gez./Drawn ProE
							Blatt/sheet 006
							Format/D.size A3

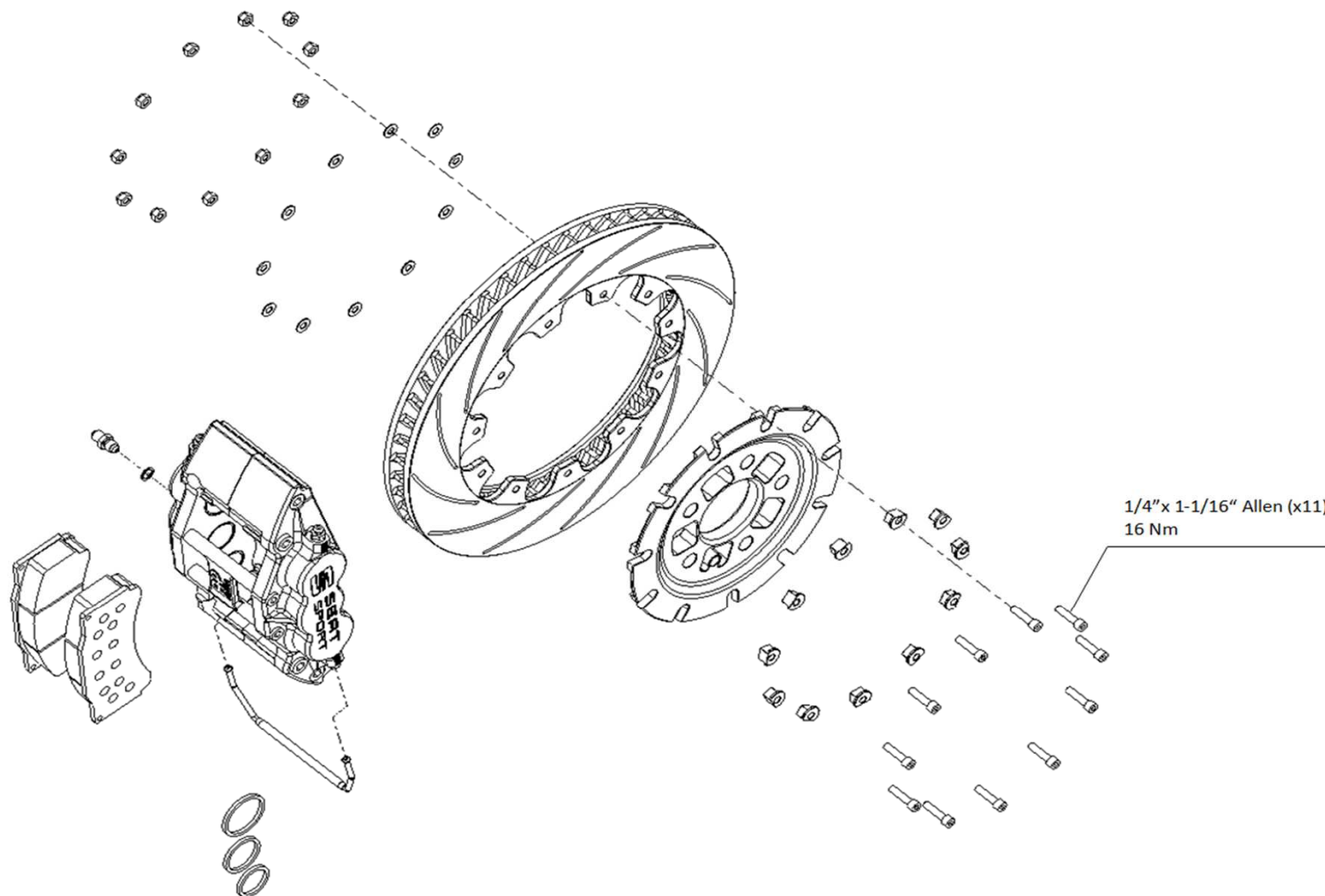
Unterlagen
References

© SEAT SPORT behält sich alle Rechte vor. Das gilt insbesondere fuer Erfindungsrechte, Know-how, Urheberrechte und Namensrechte, sowie fuer das Recht, dieses als gewerbliche Schutzrechte anzumelden. Jede Verfuugungsbefugnis ist. Están reservados todos los derechos de disposición, en especial a copiar o distribuir. © All rights remain with SEAT SPORT. This applies especially to rights of invention, know-how, copyrights and rights to name as well as for the right to patent these as commercial protective rights. All rights of disposition, particularly for copying or distributing, reserved.	Nr. No.	Datum Date	NAME	Genehmigt Appr.	Beschreibung der Aenderung und Aenderungsterminschiussel Revision record and change date code	Typ-Pruef-Dok. und Typ-Pruef-Nr./ Type-appr.-doc and type approval number	CAD-System und Verwaltungssystem - Schluessel CAD-system and administration code	Sicherheits-Dok Safety-doc.
		23/04/14	OSN	ok	Edición	Benennung Front Brake Disc	ProE	Konst.Verantw./Design resp. Name A. Almirall
						Title Front Axle		Abt./Dept. O.T.
						EA-Nr. / eng. proj. no.	V3FL	Gez./Drawn ProE Blatt/sheet 007 Format/D.size A3

Form FE Pilot 12.05a ()= Bezugsmaß Ref. Dim. []= Kontrollmaß Control dim < >= Vorrichtungsmasch Fixture dim. C = Ausfallmaß Temporary dim. □ = Pruefmasch Test dim. □ = Pruefmasch mit Bewertung Dim. To be inspected □ = Theoretisch. Masch Basic dim. > < = Werkstoff Code Material Code △ = Anziehdrehmomente Tightening torques ◇ = Proz. Mater. Proc. mater. □ = Position Position

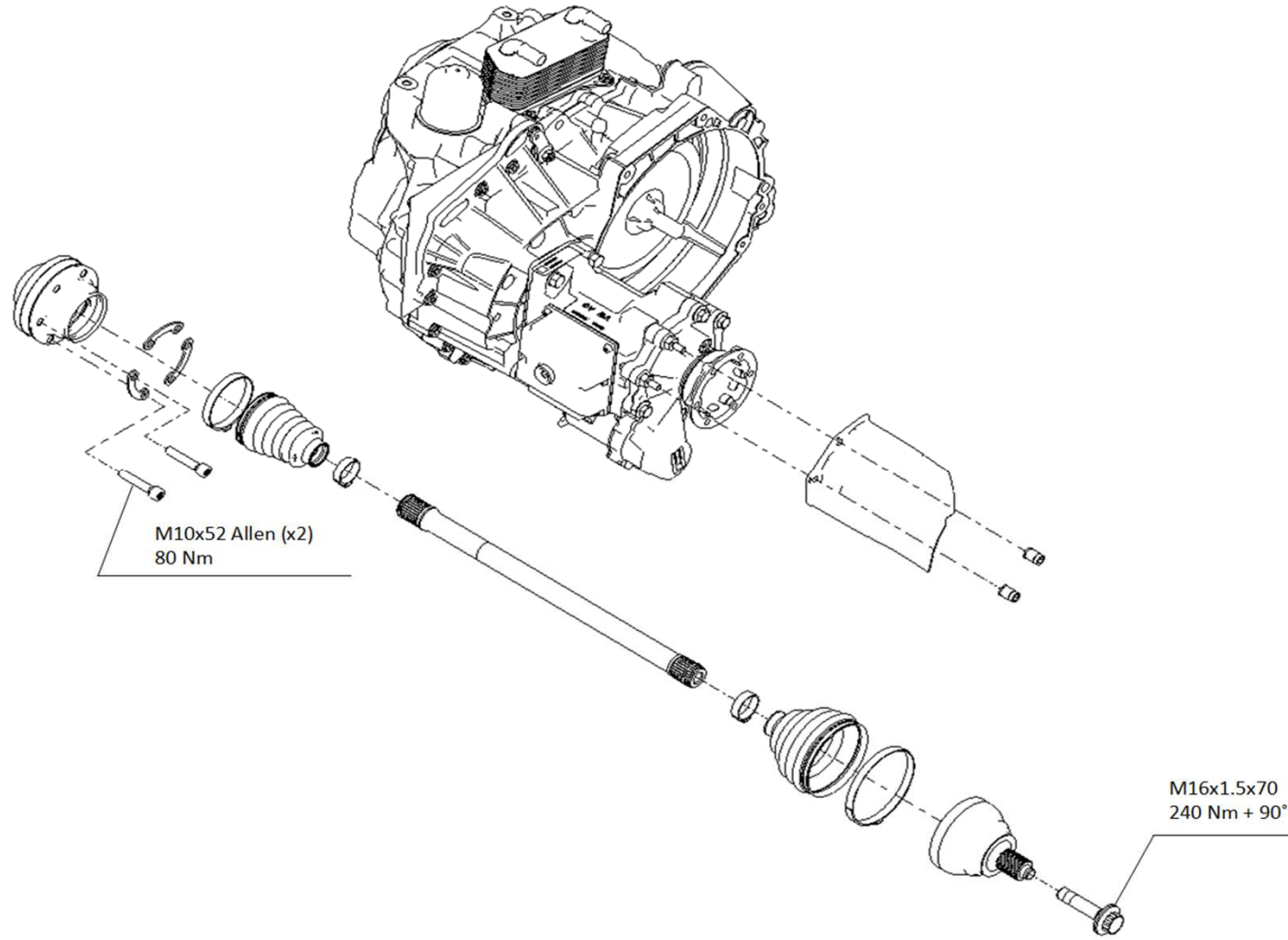
Unterlagen
References

© SEAT SPORT behält sich alle Rechte vor. Das gilt insbesondere fuer Erfindungsrechte, Know-how, Urheberrechte und Namensrechte, sowie fuer das Recht, dieses als gewerbliche Schutzrechte anzumelden. Jede Verfuugungsbefugnis ist. Están reservados todos los derechos de disposición, en especial a copiar o distribuir.

© All rights remain with SEAT SPORT. This applies especially to rights of invention, know-how, copyrights and rights to name as well as for the right to patent these as commercial protective rights. All rights of disposition, particularly for copying or distributing, reserved.

Bemerkungen / Notes

Nr. No.	Datum Date	NAME	Genehmigt Appr.	Beschreibung der Aenderung und Aenderungsterminschiussel Revision record and change date code	Typ-Pruef-Dok. und Typ-Pruef-Nr. / Type-appr.-doc and type approval number	CAD-System und Verwaltungssystem - Schluessel CAD-system and administration code	Sicherheits-Dok Safety-doc.
	23/04/14	OSN	ok	Edición		ProE	Konst.Verantw./Design resp.
					Benennung	Drive Shaft	Name A. Almirall
					Title	Front Axle	Abt./Dept. O.T.
					EA-Nr. / eng. proj. no.	V3FL	Tel.
							Gez./Drawn ProE
							Blatt/sheet 008
							Format/D.size A3

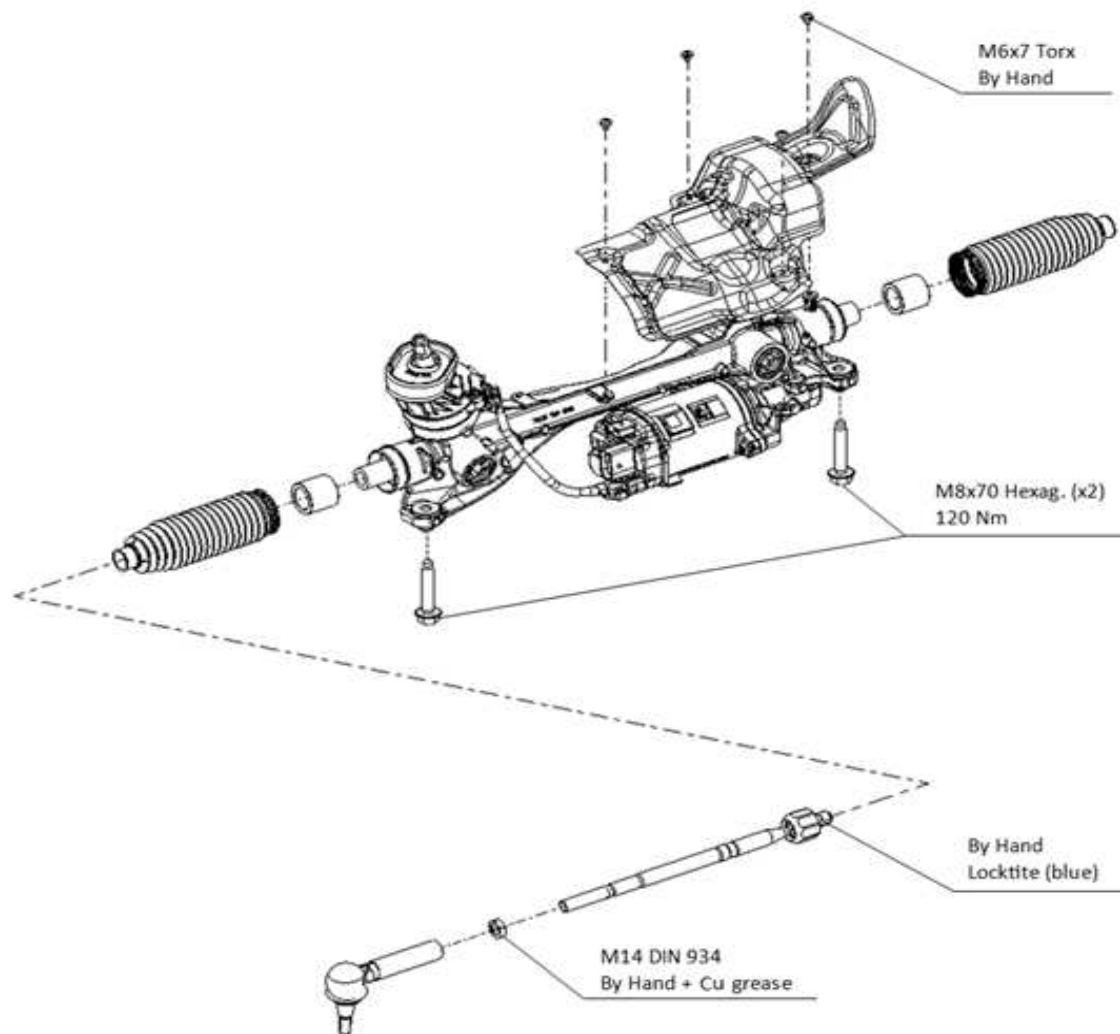
Unterlagen
References

© SEAT SPORT behält sich alle Rechte vor. Das gilt insbesondere fuer Erfindungsrechte, Know-how, Urheberrechte und Namensrechte, sowie fuer das Recht, dieses als gewerbliche Schutzrechte anzumelden. Jede Verfuegungsbefugnis ist. Están reservados todos los derechos de disposición, en especial a copiar o distribuir. © All rights remain with SEAT SPORT. This applies especially to rights of invention, know-how, copyrights and rights to name as well as for the right to patent these as commercial protective rights. All rights of disposition, particularly for copying or distributing, reserved.	Nr. No.	Datum Date	NAME	Genehmigt Appr.	Beschreibung der Aenderung und Aenderungsterminschiuesel Revision record and change date code	Typ-Pruef-Dok. und Typ-Pruef-Nr./ Type-appr.-doc and type approval number	CAD-System und Verwaltungssystem - Schluessel CAD-system and administration code	Sicherheits-Dok Safety-doc.
		23/04/14	OSN	ok	Edición	Benennung Steering Rack	ProE	Konst.Verantw./Design resp. Name A. Almirall
Bemerkungen / Notes						Title Front Axle		Abt./Dept. O.T.
						EA-Nr. / eng. proj. no.	V3FL	Tel. Gez./Drawn ProE Blatt/sheet 009 Format/D.size A3

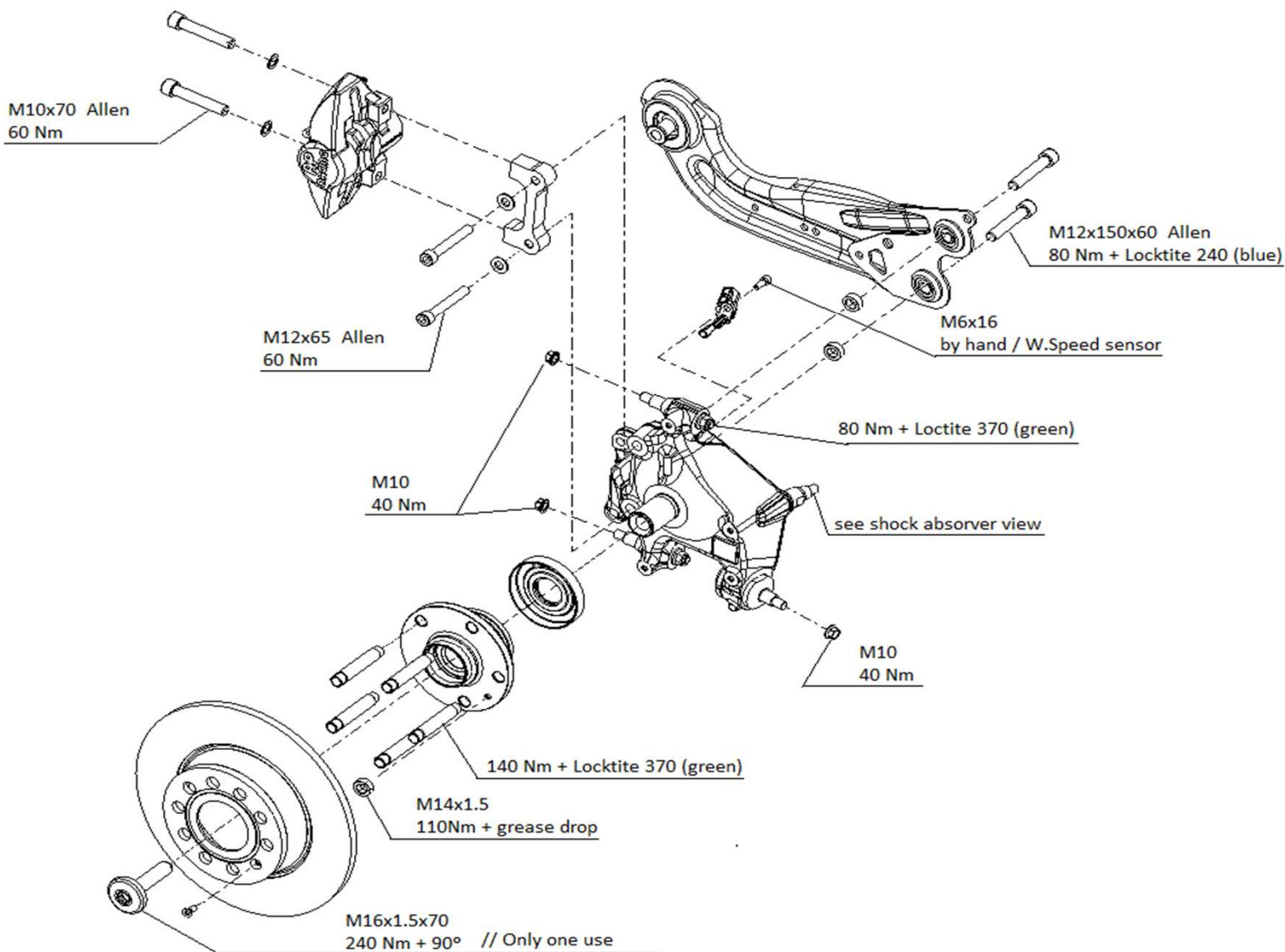
Unterlagen
References

© SEAT SPORT behält sich alle Rechte vor. Das gilt insbesondere fuer Erfindungsrechte, Know-how, Urheberrechte und Namensrechte, sowie fuer das Recht, dieses als gewerbliche Schutzrechte anzumelden. Jede Verfuugungsbefugnis ist. Están reservados todos los derechos de disposición, en especial a copiar o distribuir.

© All rights remain with SEAT SPORT. This applies especially to rights of invention, know-how, copyrights and rights to name as well as for the right to patent these as commercial protective rights. All rights of disposition, particularly for copying or distributing, reserved.

Bemerkungen / Notes

Nr. No.	Datum Date	NAME	Genehmigt Appr.	Beschreibung der Aenderung und Aenderungsterminschiussel Revision record and change date code	Typ-Pruef-Dok. und Typ-Pruef-Nr. / Type-appr.- doc and type approval number	CAD-System und Verwaltungssystem - Schluessel CAD-system and administration code	Sicherheits-Dok Safety-doc.
	23/04/14	OSN	ok	Edición		ProE	Konst.Verantw./Design resp.
					Benennung	Rear Wheel Hub Assy.	Name A. Almirall
					Title	Rear Axle	Abt./Dept. O.T.
					EA-Nr. / eng. proj. no.	V3FL	Tel.
							Gez./Drawn ProE
							Blatt/sheet 010
							Format/D.size A3

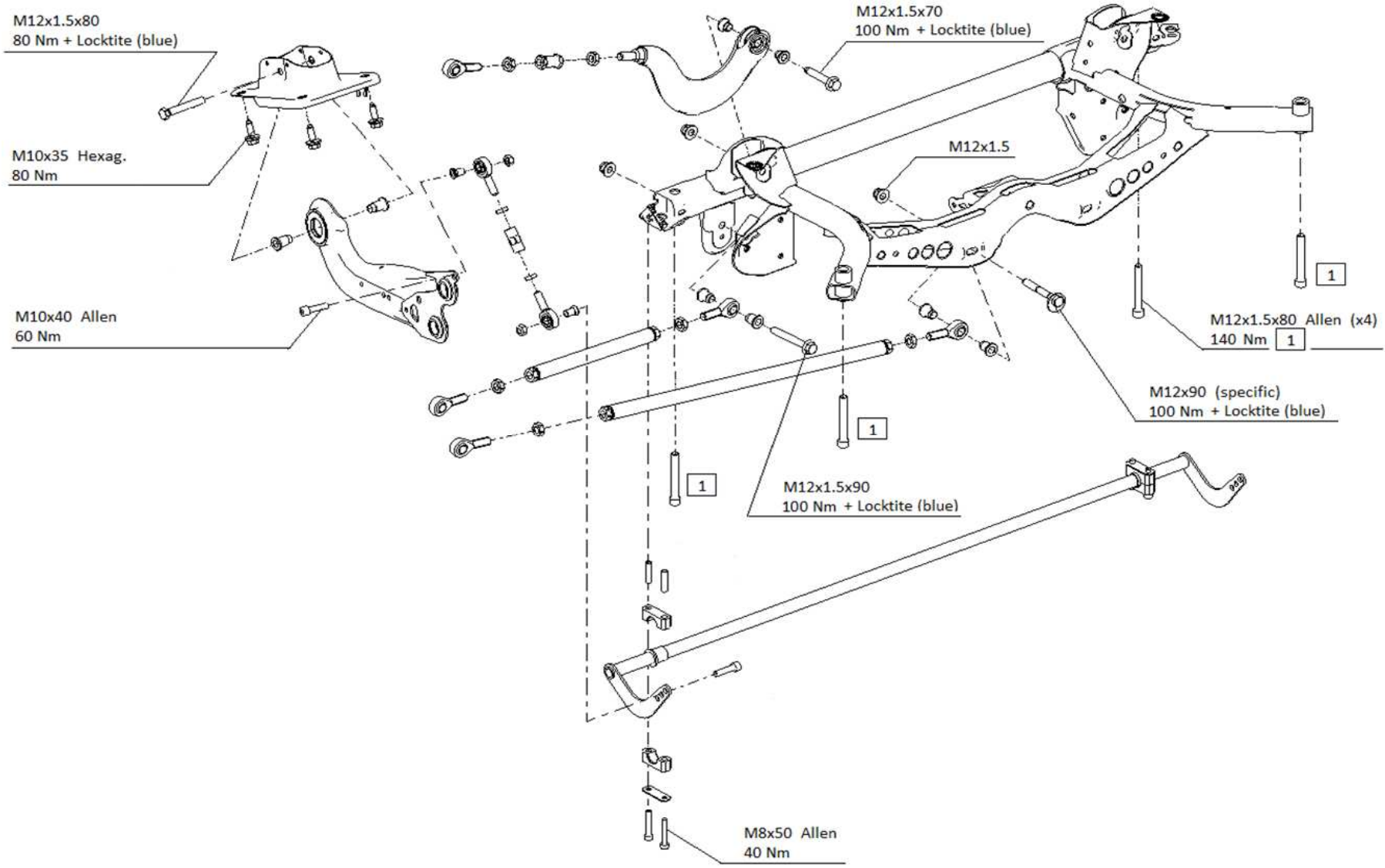
Unterlagen
References

© SEAT SPORT behält sich alle Rechte vor. Das gilt insbesondere fuer Erfindungsrechte, Know-how, Urheberrechte und Namensrechte, sowie fuer das Recht, dieses als gewerbliche Schutzrechte anzumelden. Jede Verfuugungsbefugnis ist. Están reservados todos los derechos de disposición, en especial a copiar o distribuir.

© All rights remain with SEAT SPORT. This applies especially to rights of invention, know-how, copyrights and rights to name as well as for the right to patent these as commercial protective rights. All rights of disposition, particularly for copying or distributing, reserved.

Nr. No.	Datum Date	NAME	Genehmigt Appr.	Beschreibung der Aenderung und Aenderungsterminschiussel Revision record and change date code
	23/04/14	OSN	ok	Edición

Typ-Pruef-Dok. und Typ-Pruef-Nr. / Type-appr. - doc and type approval number	CAD-System und Verwaltungssystem - Schluessel CAD-system and administration code	Sicherheits-Dok Safety-doc.
ProE		Konst.Verantw./Design resp.
Benennung Rear Axle Assembly		Name A. Almirall
Title Rear Axle		Abt./Dept. O.T.
EA-Nr. / eng. proj. no.		Tel.
V3FL		Gez./Drawn ProE
		Blatt/sheet 011
		Format/D.size A3

Bemerkungen / Notes

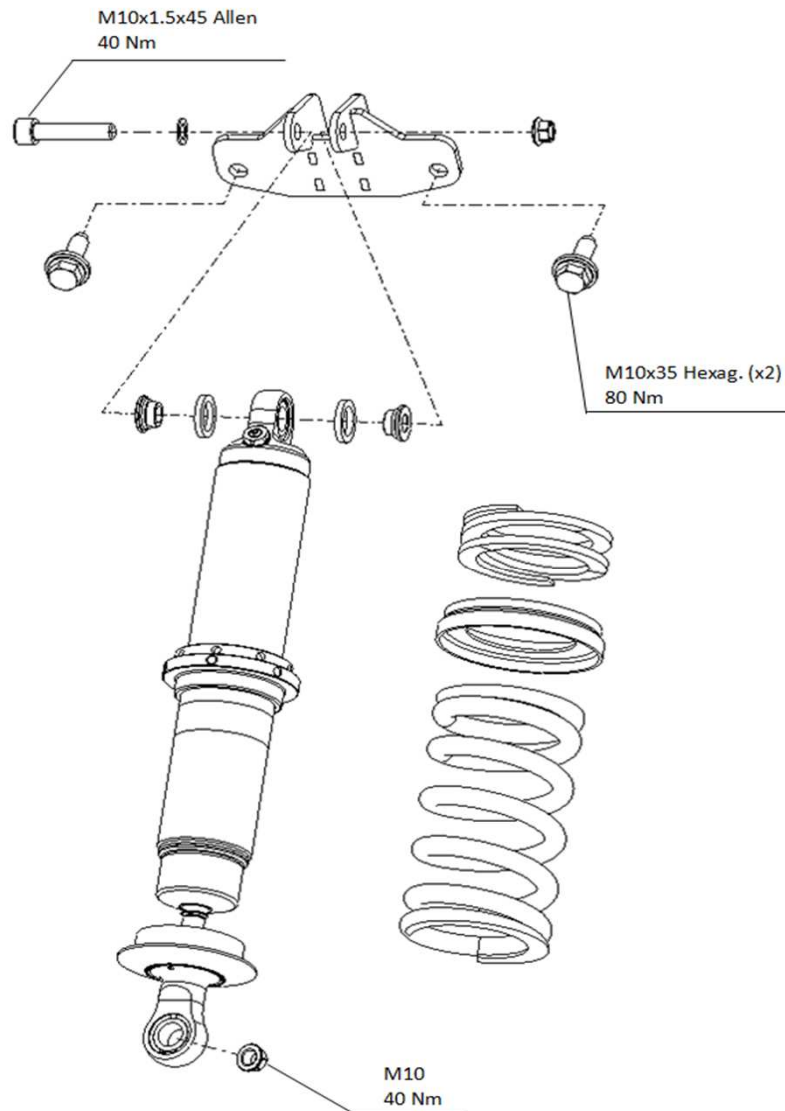
Unterlagen
References

© SEAT SPORT behält sich alle Rechte vor. Das gilt insbesondere fuer Erfindungsrechte, Know-how, Urheberrechte und Namensrechte, sowie fuer das Recht, dieses als gewerbliche Schutzrechte anzumelden. Jede Verfuegungsbefugnis ist. Están reservados todos los derechos de disposición, en especial a copiar o distribuir.
 © All rights remain with SEAT SPORT. This applies especially to rights of invention, know-how, copyrights and rights to name as well as for the right to patent these as commercial protective rights. All rights of disposition, particularly for copying or distributing, reserved.

Nr. No.	Datum Date	NAME	Genehmigt Appr.	Beschreibung der Aenderung und Aenderungsterminschiussel Revision record and change date code	Typ-Pruef-Dok. und Typ-Pruef-Nr./ Type-appr.- doc and type approval number	CAD-System und Verwaltungssystem - Schluessel CAD-system and administration code	Sicherheits-Dok Safety-doc.
	23/04/14	OSN	ok	Edición		ProE	Konst.Verantw./Design resp.
Bemerkungen / Notes					Benennung Rear Shock Absorber		Name A. Almirall
					Title Rear Axle		Abt./Dept. O.T.
					EA-Nr. / eng. proj. no.		Tel.
					V3FL		Gez./Drawn ProE
					Blatt/sheet 012		Format/D.size A3

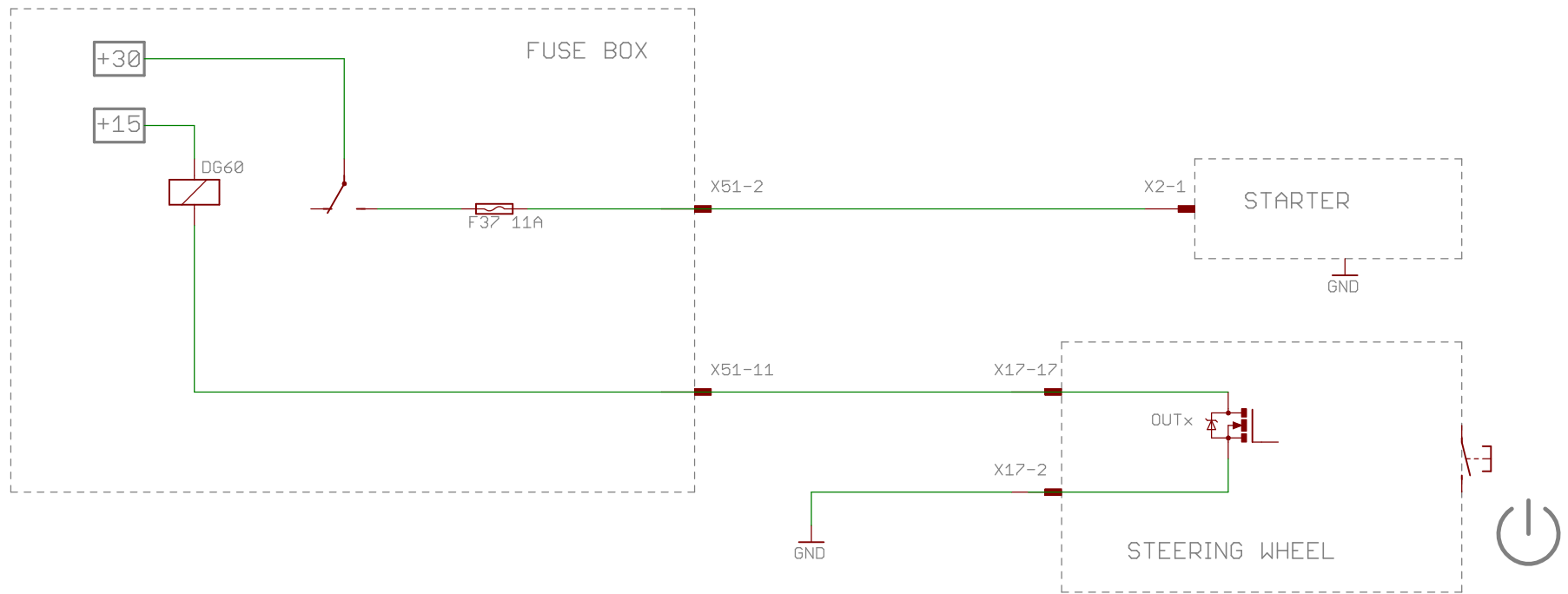

SEAT Sport

by TH0tronic

TITLE: MK3_schematic_details

Document Number: STARTER

REV:

Date: 02/06/2014 17:50:44

Sheet: 1/26

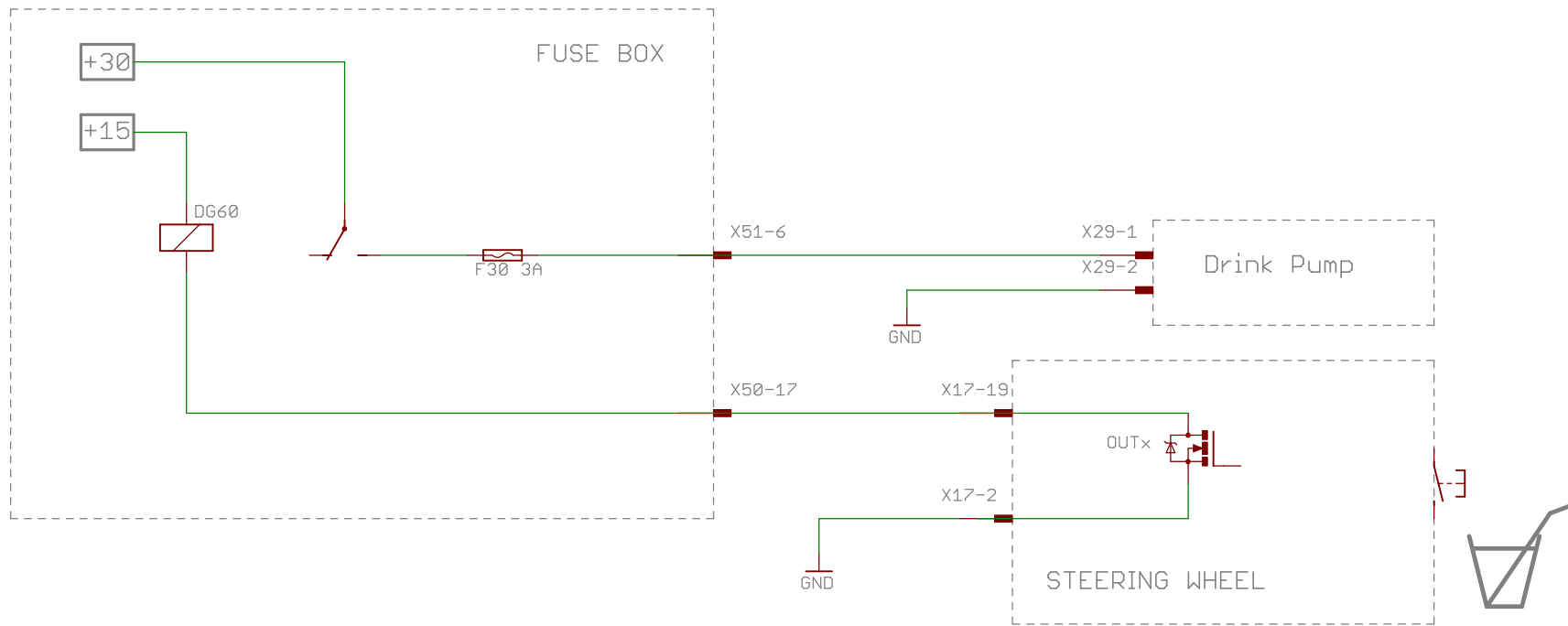

SEAT Sport		by THQtronic
TITLE: MK3_schematic_details		
Document Number:	DRINK	REV:
Date: 02/06/2014 17:50:44	Sheet: 2/26	

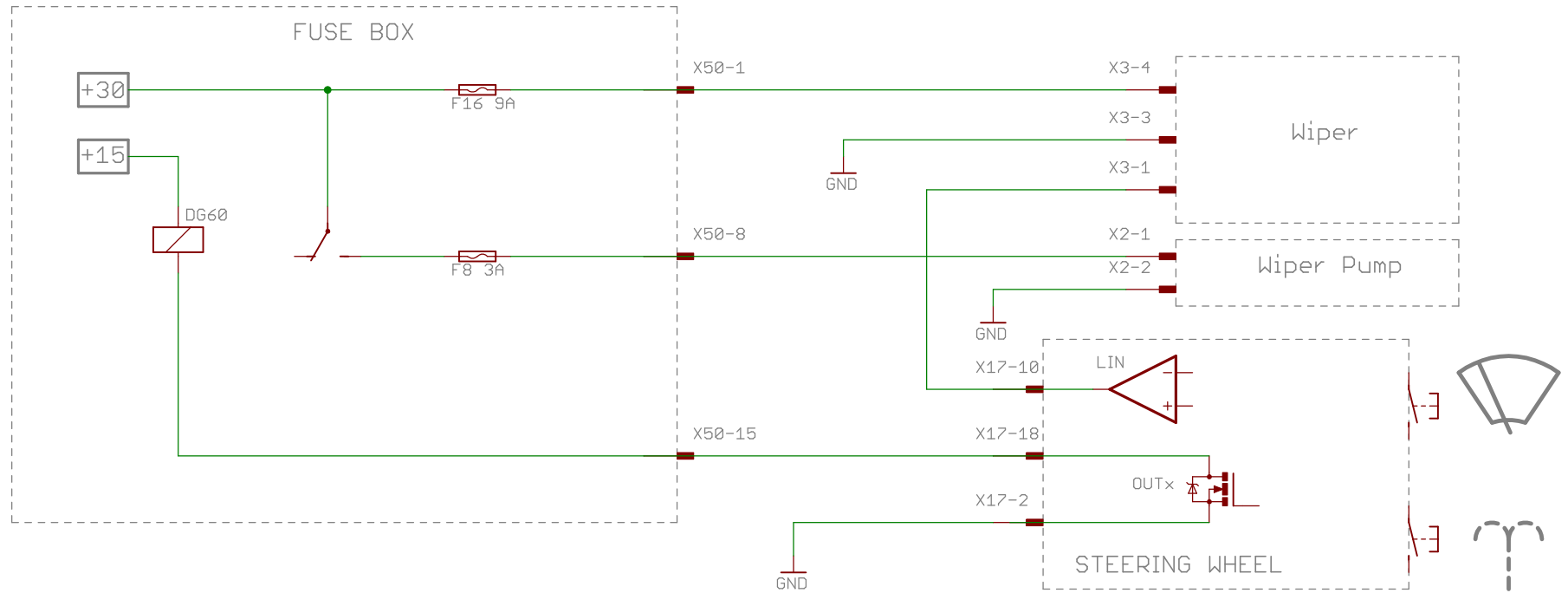

SEAT Sport

by THQtronic

TITLE: MK3_schematic_details

Document Number: WIPER

REV:

Date: 02/06/2014 17:50:44

Sheet: 3/26

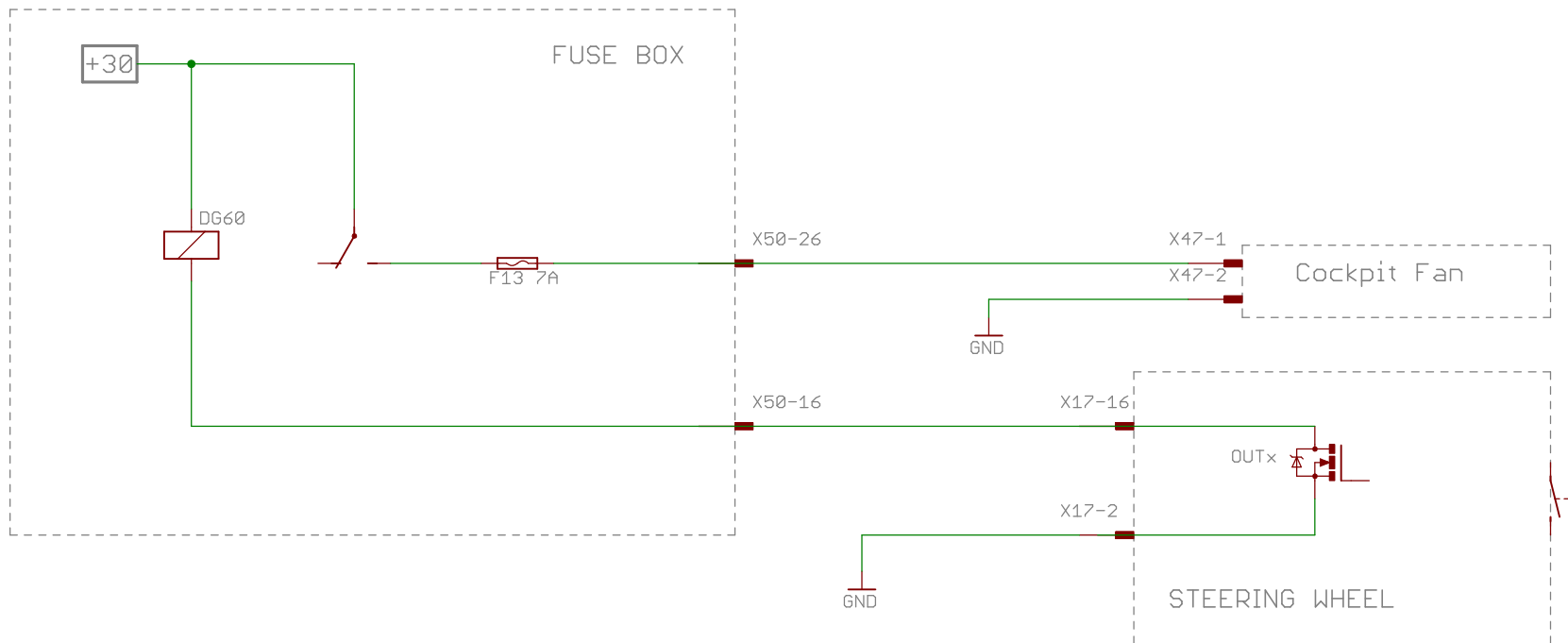

SEAT Sport		by THQtronic
TITLE: MK3_schematic_details		
Document Number:	Cockpit FAN	REV:
Date: 02/06/2014 17:50:44	Sheet: 4/26	

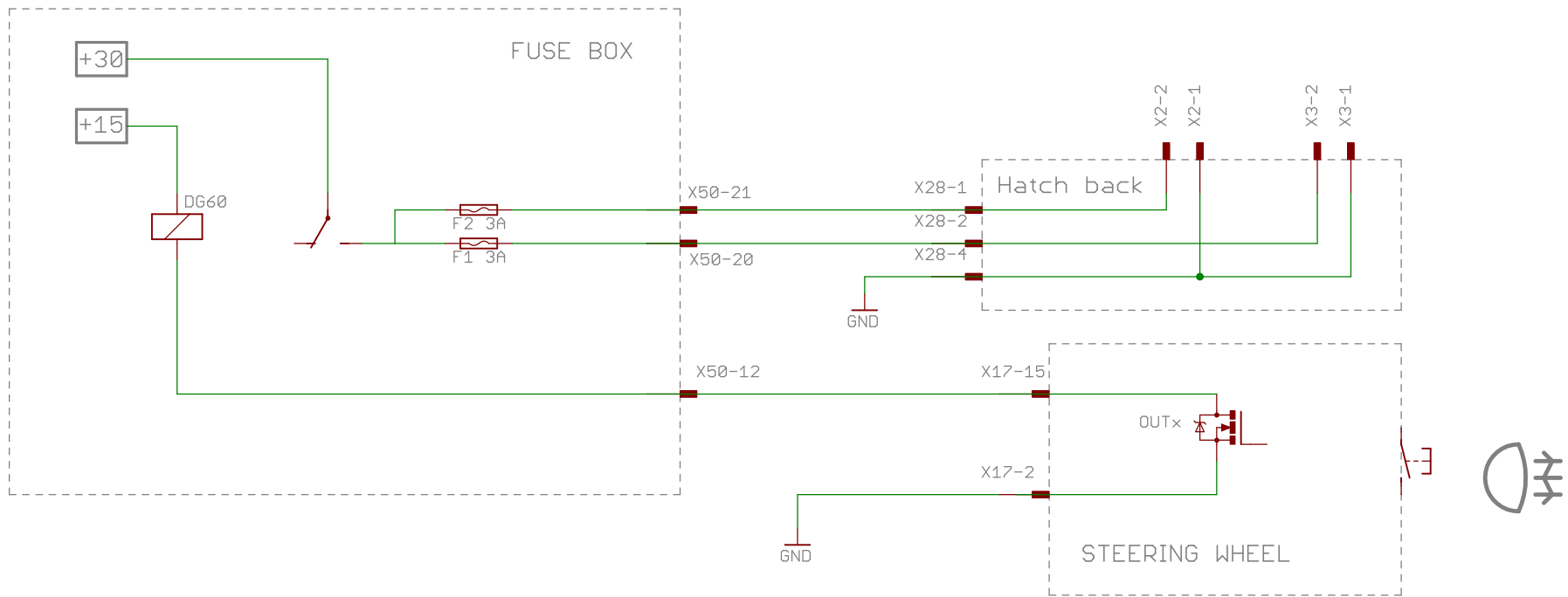

SEAT Sport

by THQtronic

TITLE: MK3_schematic_details

Document Number: Rain Light

REV:

Date: 02/06/2014 17:50:44

Sheet: 5/26

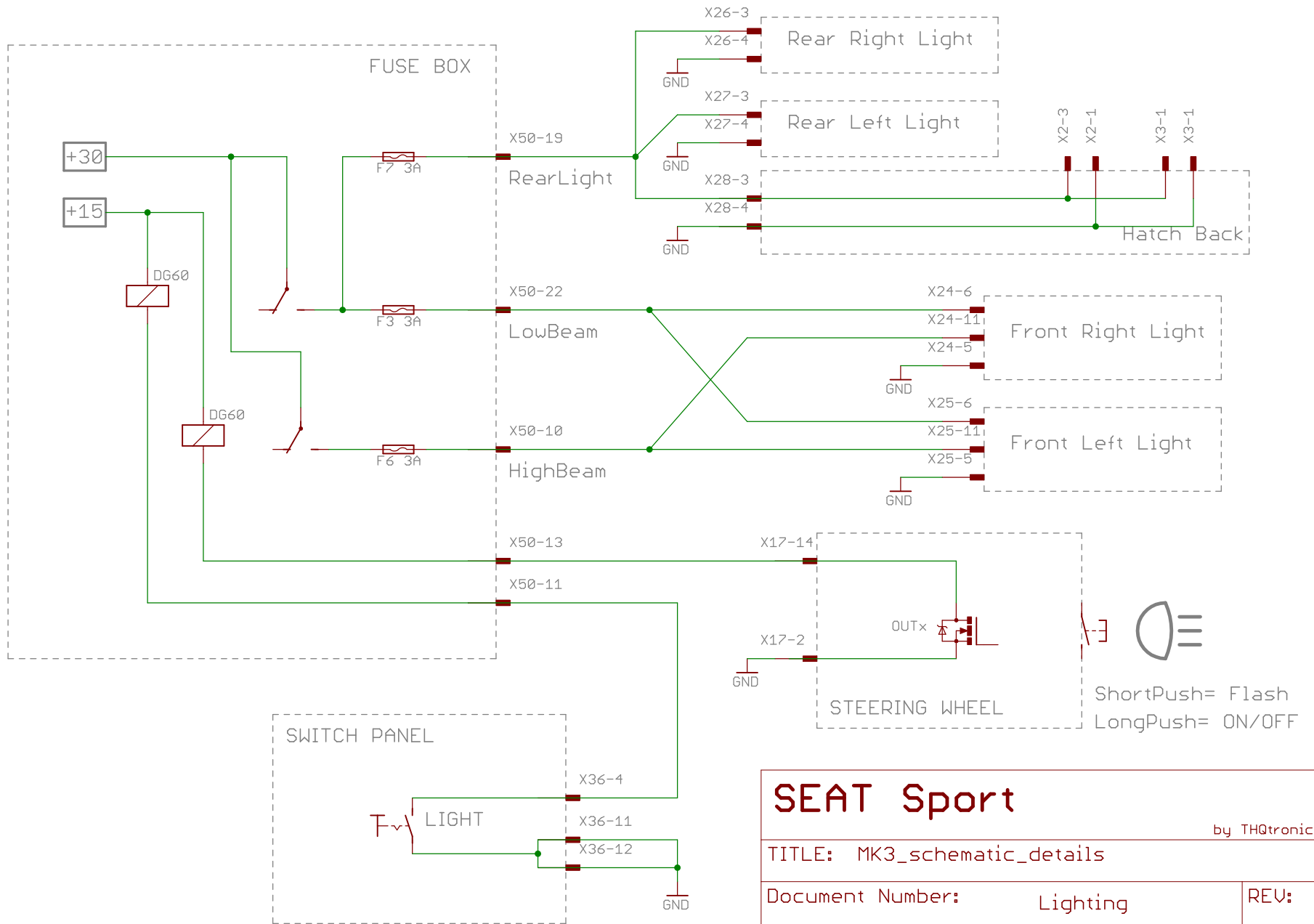

SEAT Sport

by THQtronic

TITLE: MK3_schematic_details

Document Number: Lighting

REV:

Date: 02/06/2014 17:50:44

Sheet: 6/26

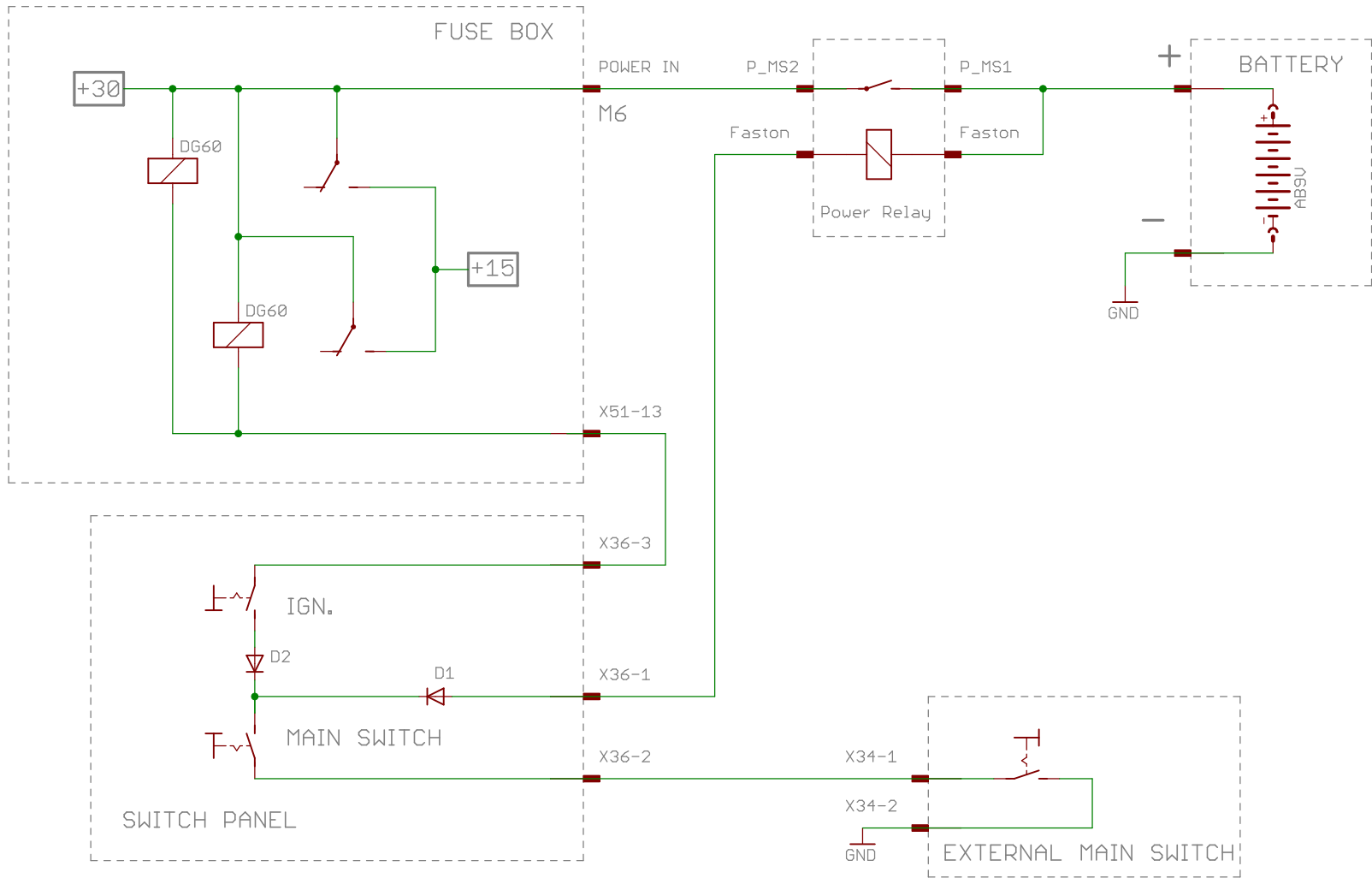

SEAT Sport

by THQtronic

TITLE: MK3_schematic_details

Document Number: MainSwitch / Ignition REV:

Date: 02/06/2014 17:50:44

Sheet: 7/26

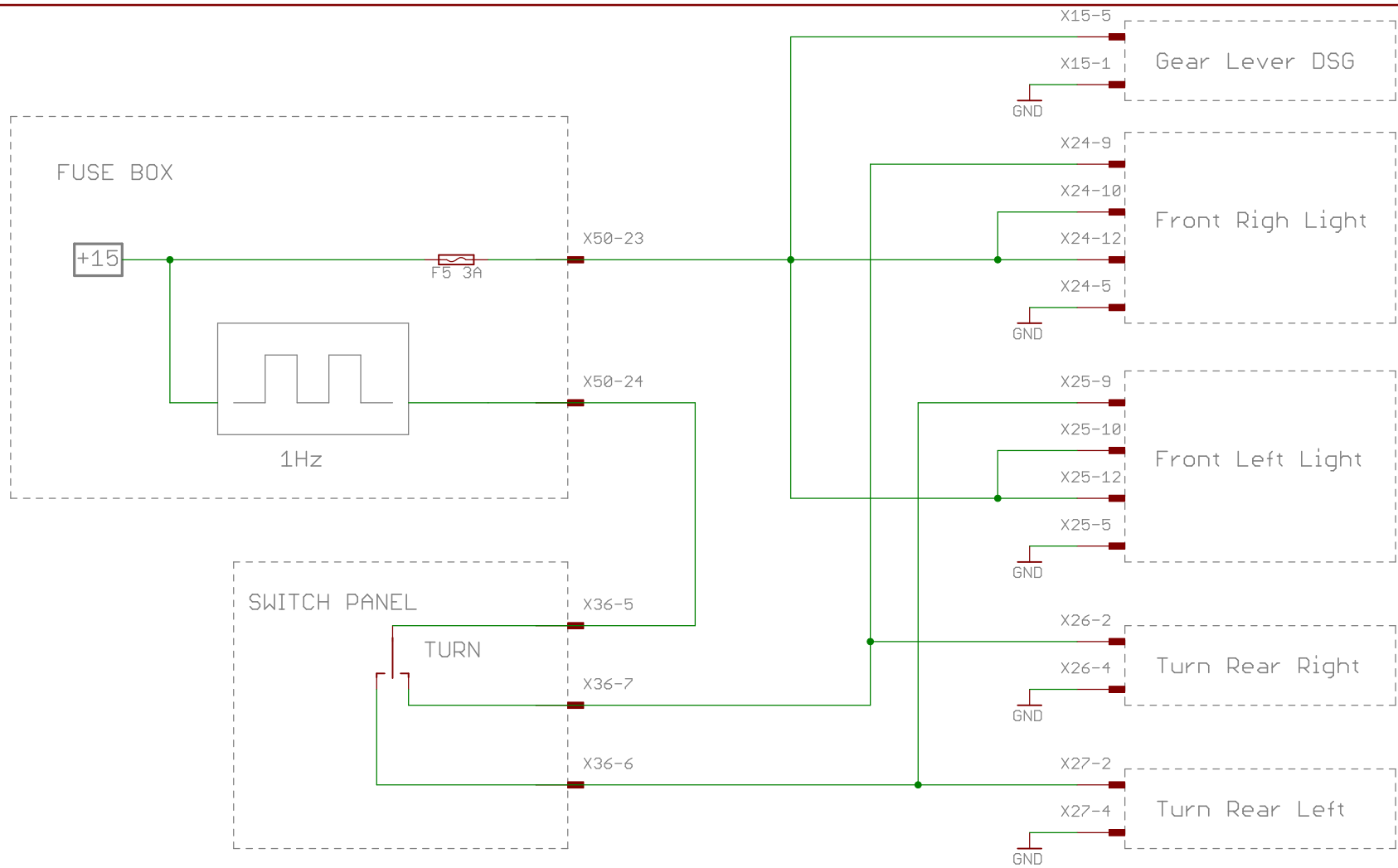

SEAT Sport

by THQtronic

TITLE: MK3_schematic_details

Document Number: Turn and Day Light REV:

Date: 02/06/2014 17:50:44

Sheet: 8/26

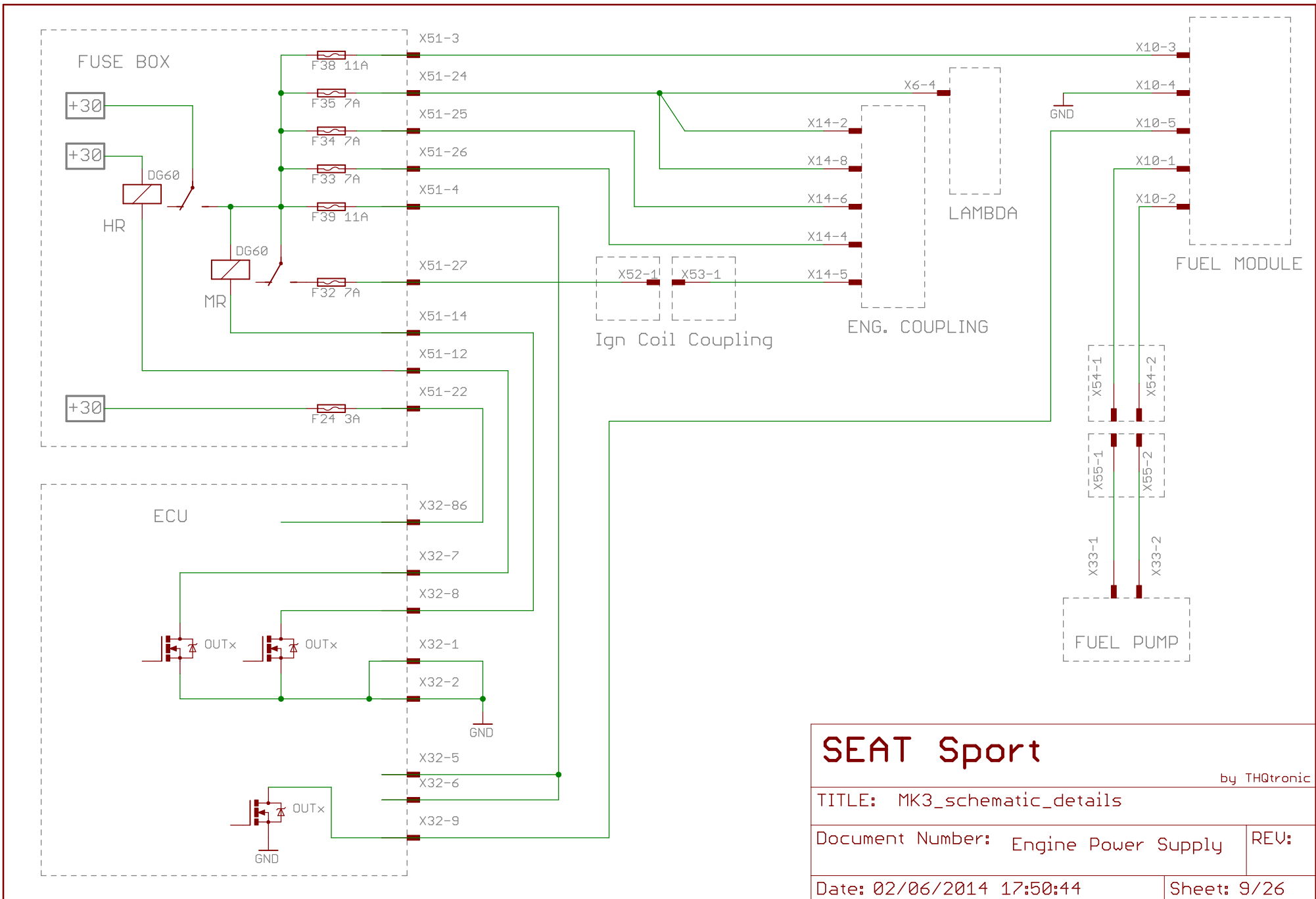

SEAT Sport

by THQtronic

TITLE: MK3_schematic_details

Document Number: Engine Power Supply

REV:

Date: 02/06/2014 17:50:44

Sheet: 9/26

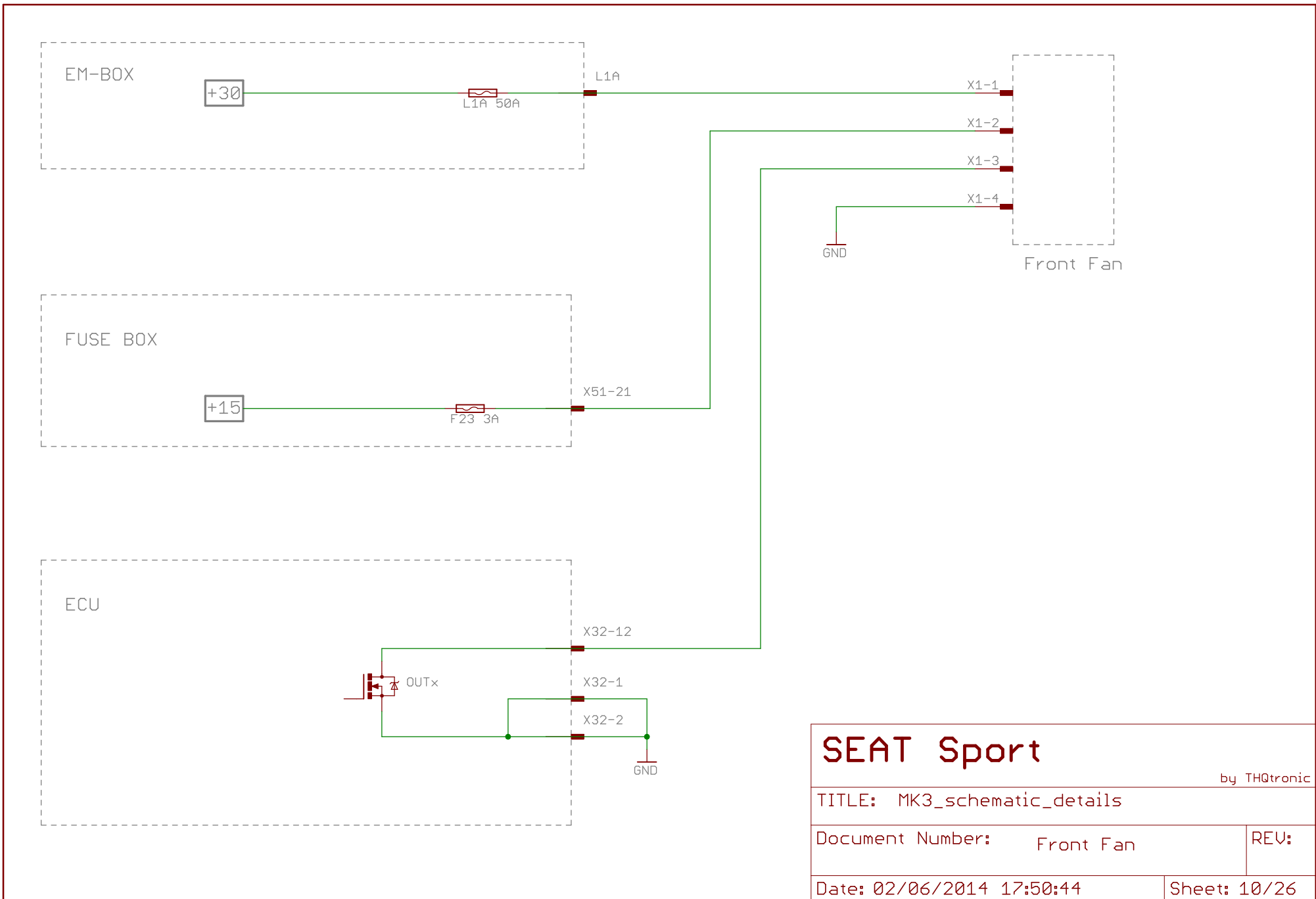

SEAT Sport

by THQtronic

TITLE: MK3_schematic_details

Document Number: Front Fan

REV:

Date: 02/06/2014 17:50:44

Sheet: 10/26

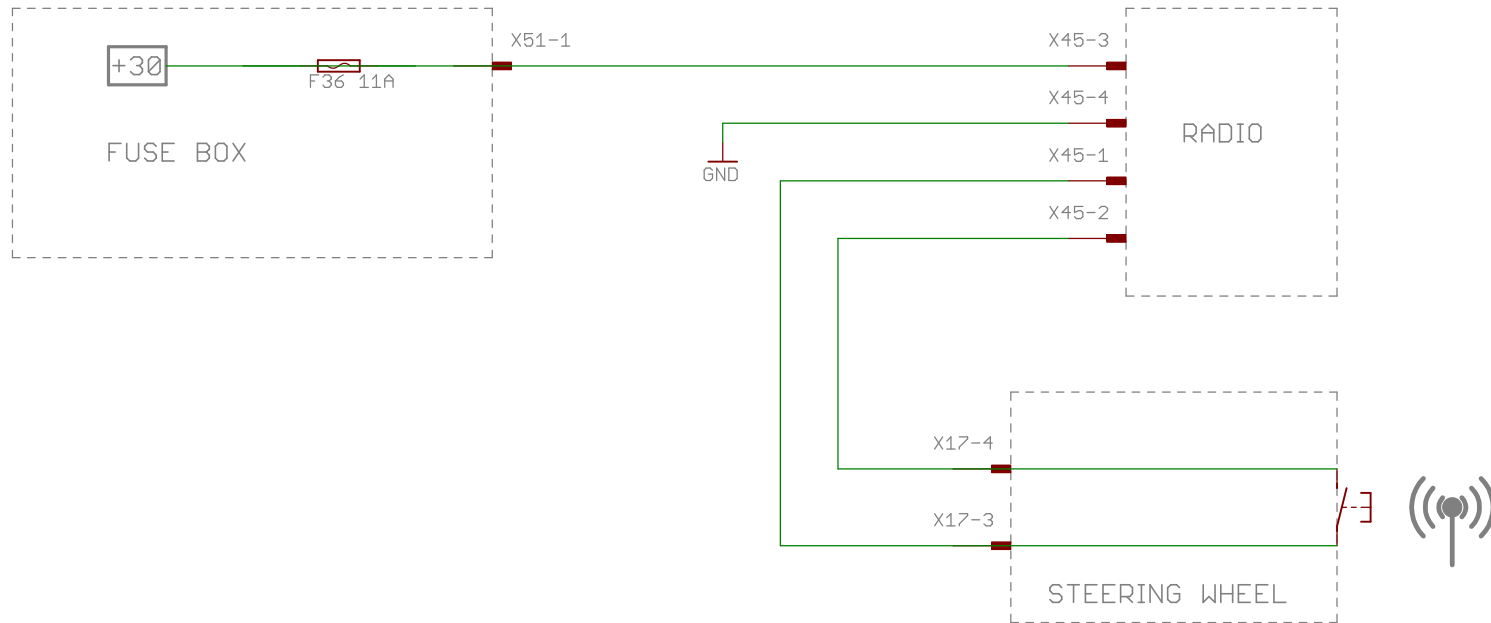

SEAT Sport

by THQtronic

TITLE: MK3_schematic_details

Document Number: Radio

REV:

Date: 02/06/2014 17:50:44

Sheet: 11/26

KSK

DOOR WIRING

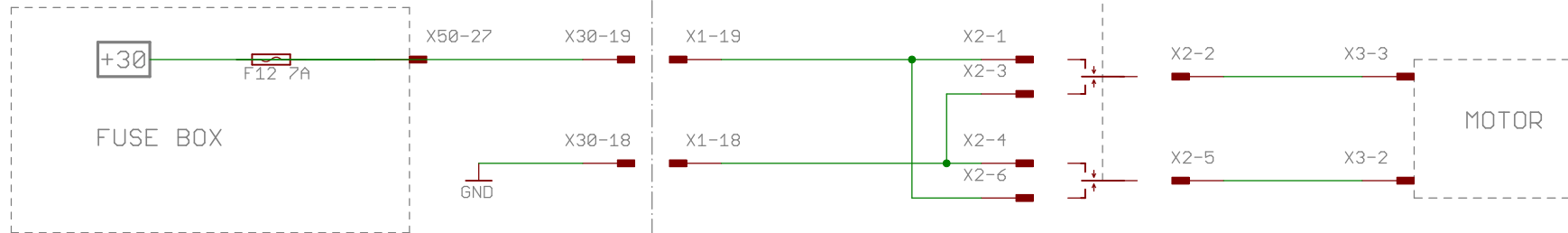

SEAT Sport

by THQtronic

TITLE: MK3_schematic_details

Document Number: Window

REV:

Date: 02/06/2014 17:50:44

Sheet: 12/26

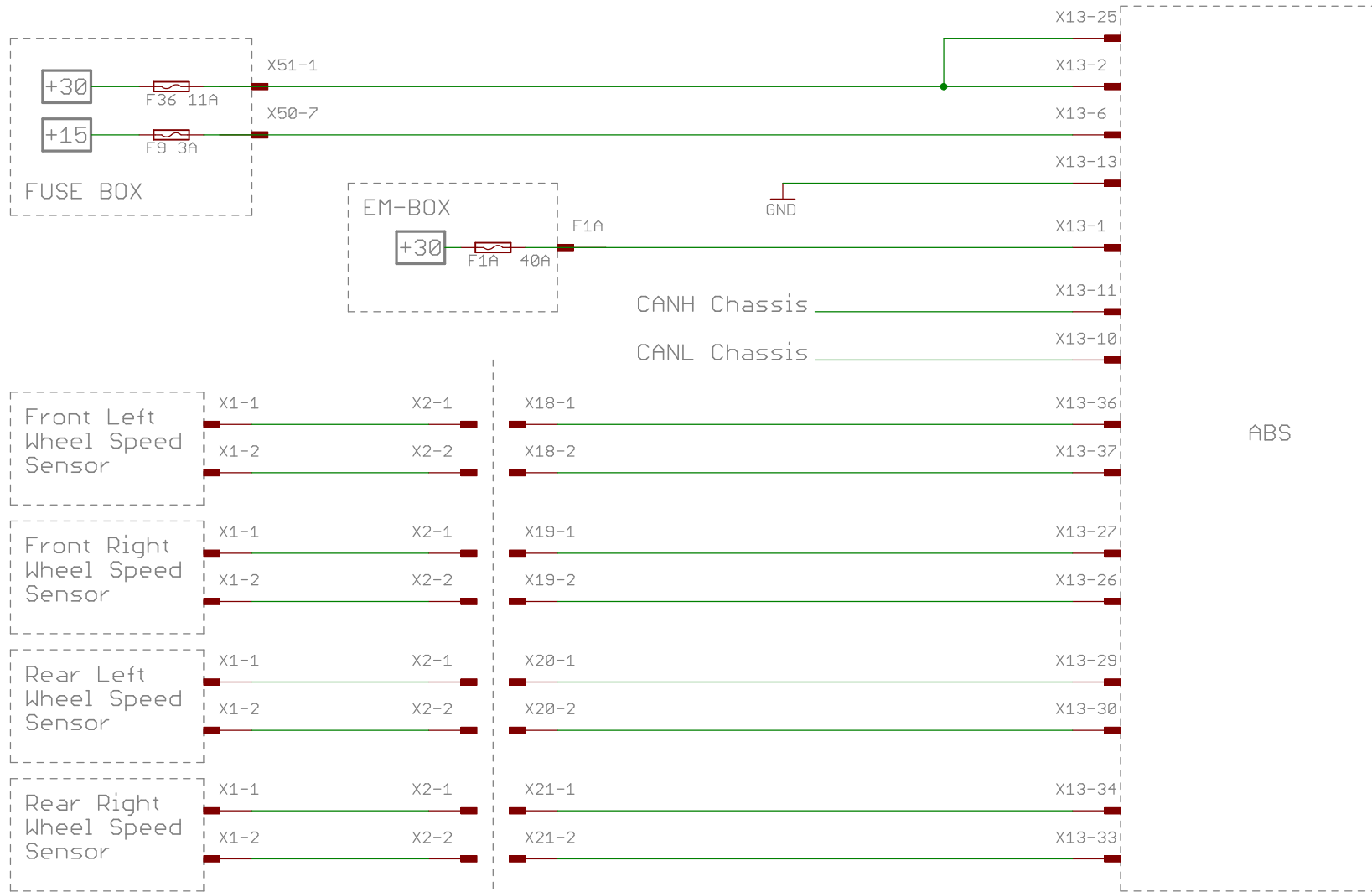

SEAT Sport

by THQtronic

TITLE: MK3_schematic_details

Document Number: ABS

REV:

Date: 02/06/2014 17:50:44

Sheet: 13/26

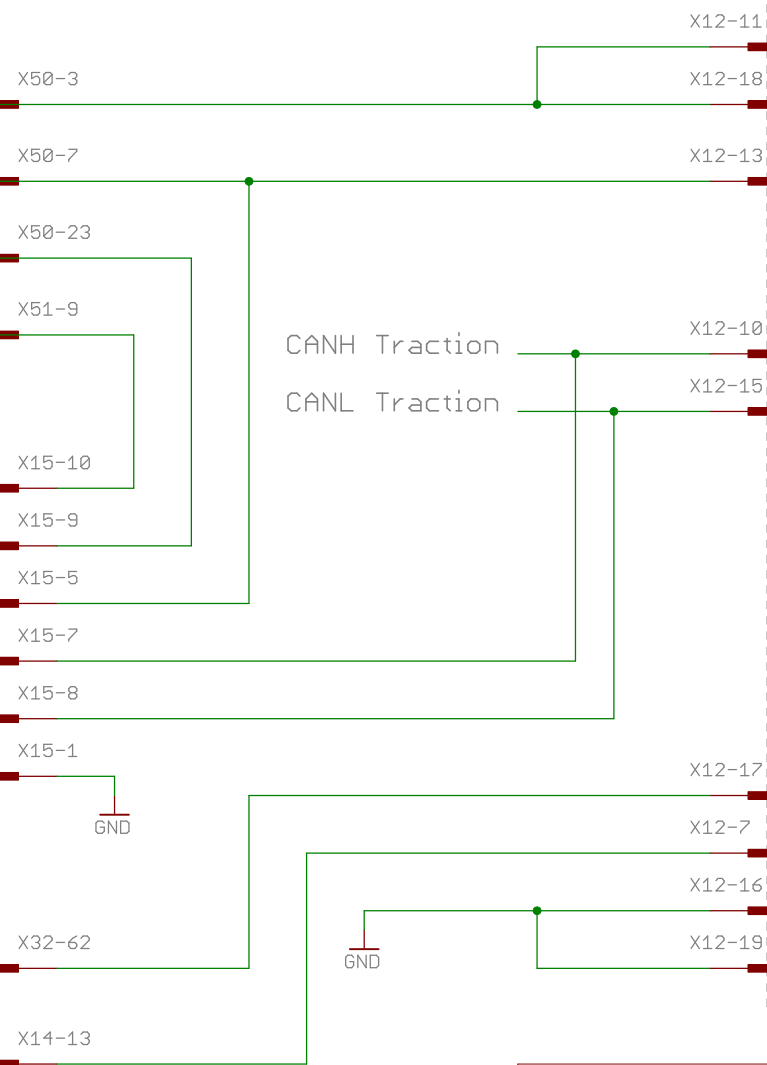
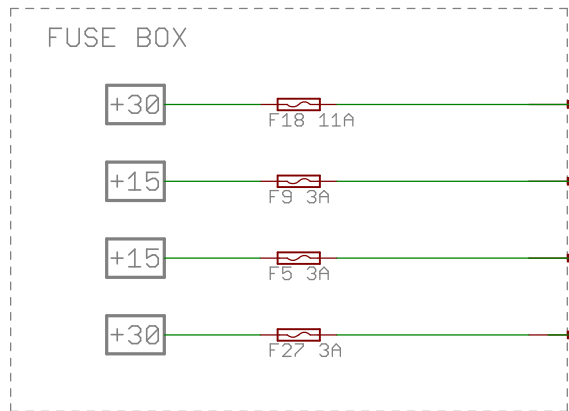

SEAT Sport

by THQtronic

TITLE: MK3_schematic_details

Document Number: DSG

REV:

Date: 02/06/2014 17:50:44

Sheet: 14/26

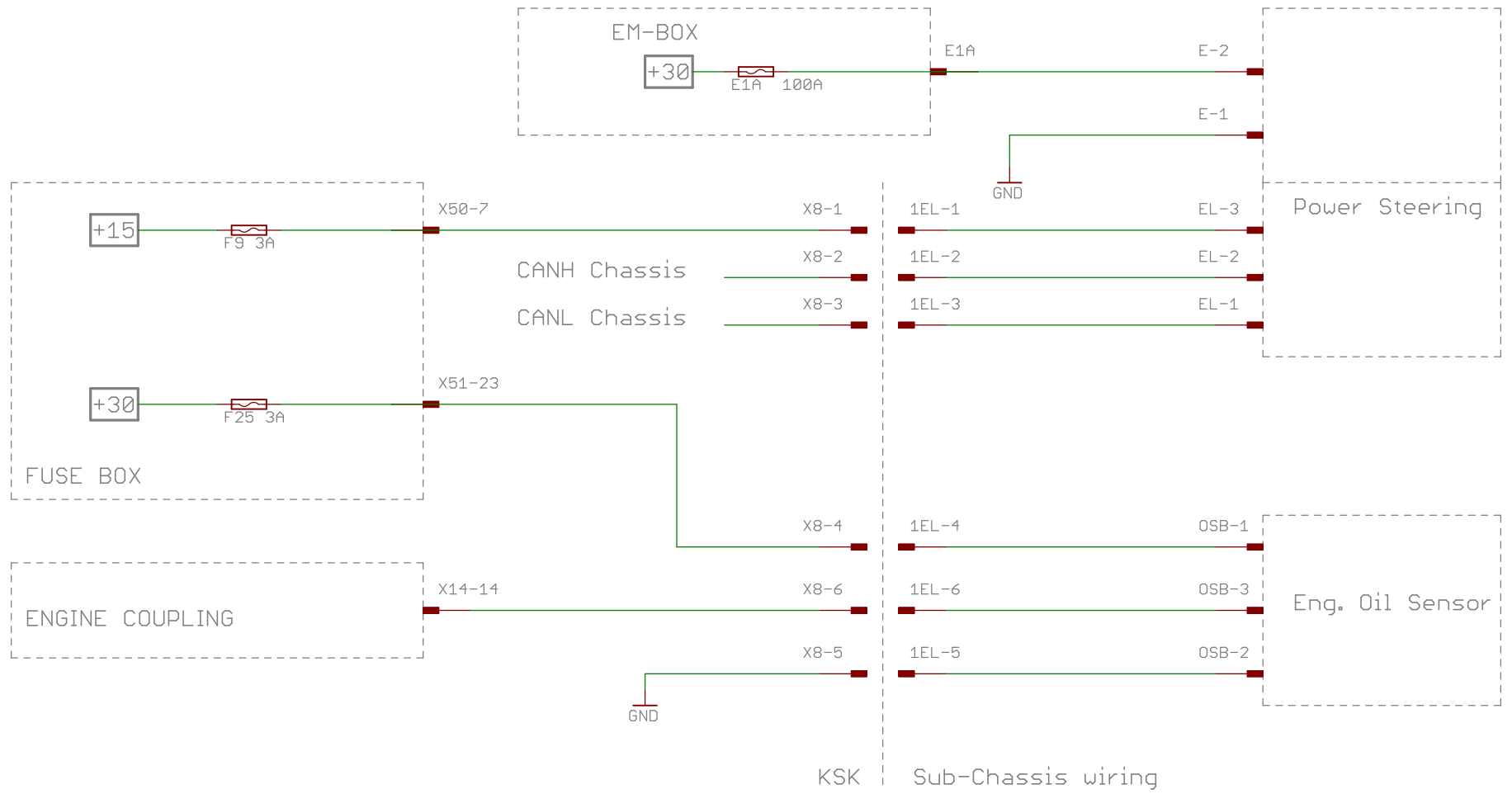

<h1>SEAT Sport</h1>		by THQtronic
TITLE: MK3_schematic_details		
Document Number:	POWER STEERING	REV:
Date: 02/06/2014 17:50:44	Sheet: 15/26	

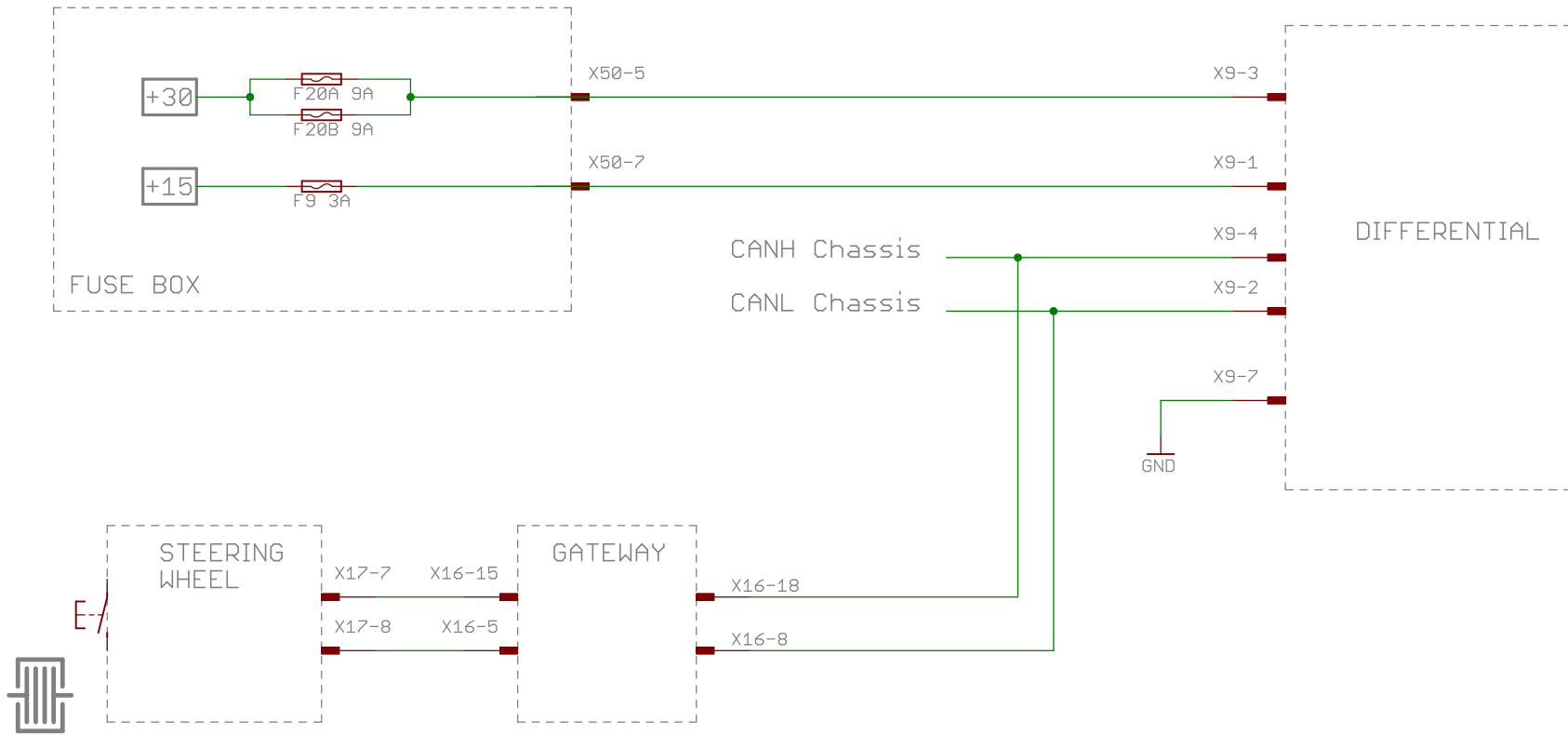

SEAT Sport		by THQtronic
TITLE: MK3_schematic_details		
Document Number:	DIFFERENTIAL	REV:
Date: 02/06/2014 17:50:44	Sheet: 16/26	

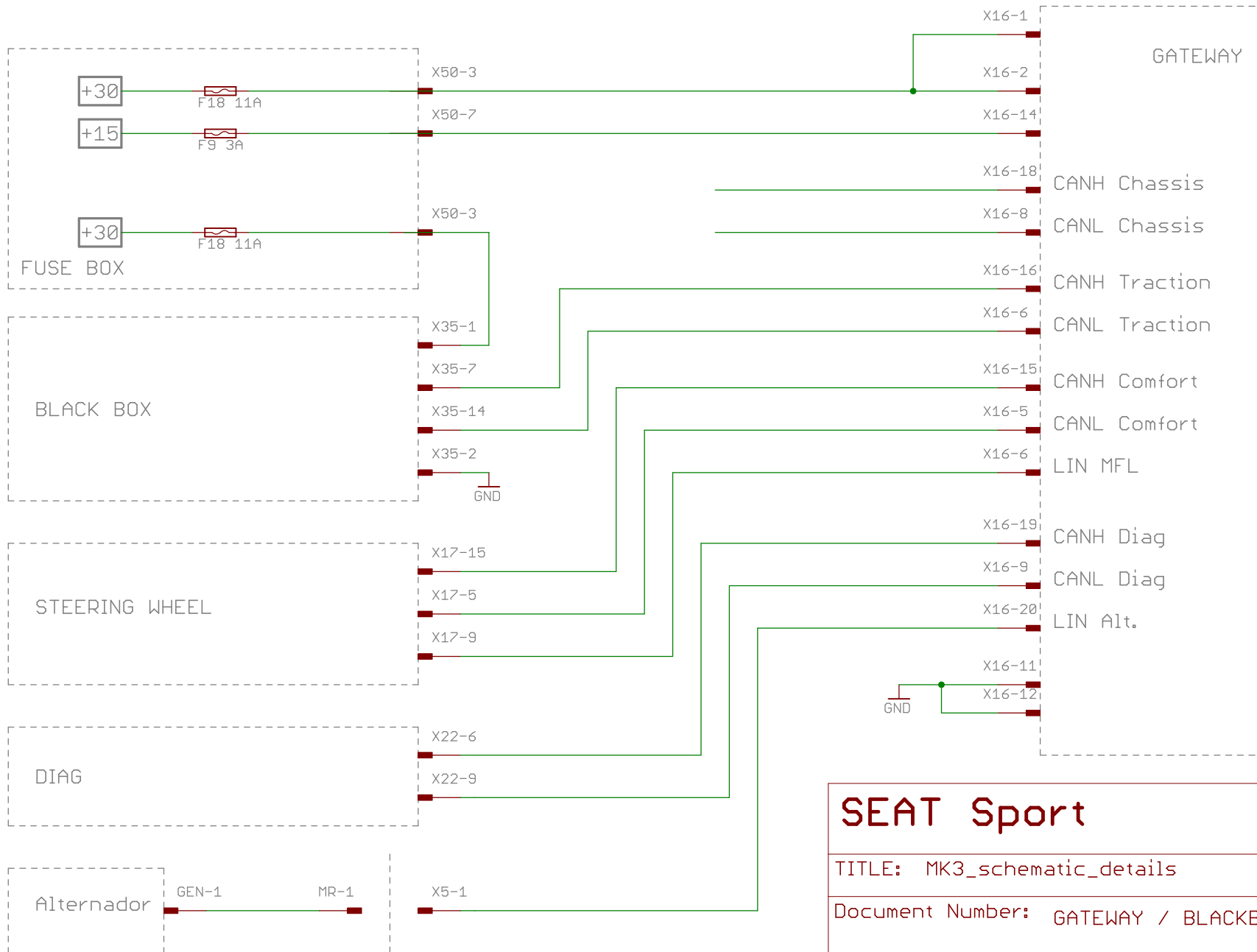

SEAT Sport

by THQtronic

TITLE: MK3_schematic_details

Document Number: GATEWAY / BLACKBOX

REV:

Date: 02/06/2014 17:50:44

Sheet: 17/26

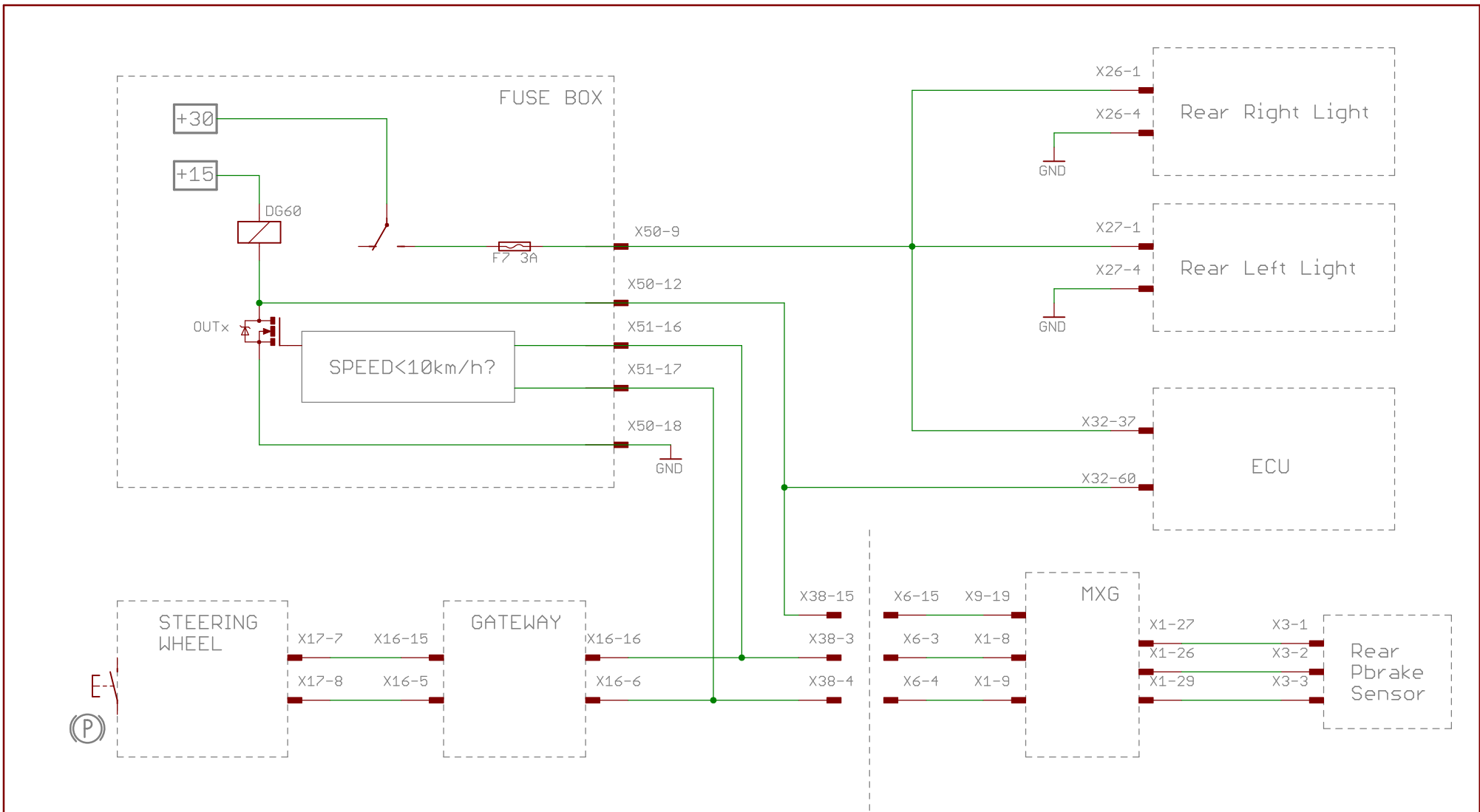

<h1>SEAT Sport</h1>		by THQtronic
TITLE: MK3_schematic_details		
Document Number:	Brake Light	REV:
Date: 02/06/2014 17:50:44	Sheet: 18/26	

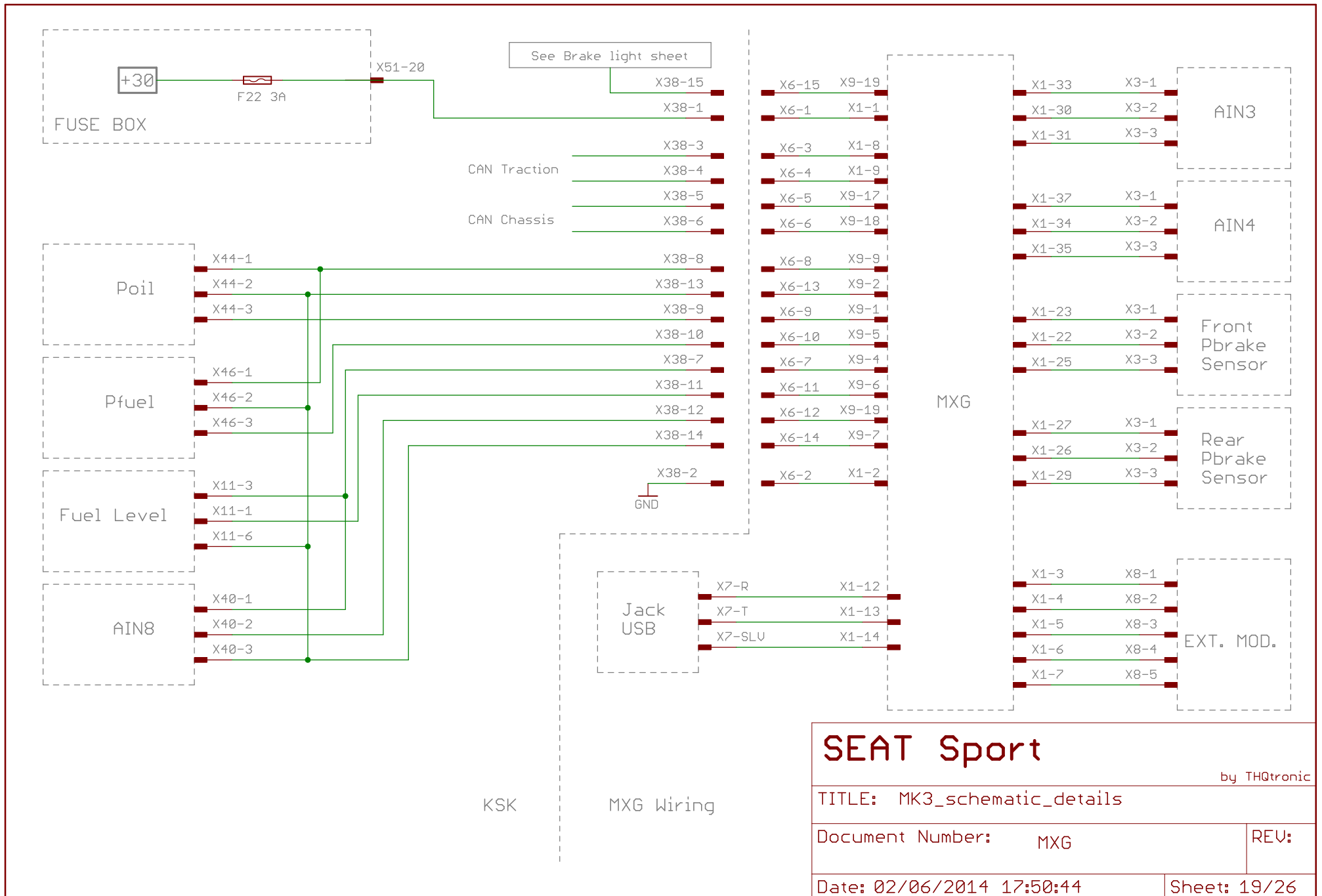

SEAT Sport by THQtronic

TITLE: MK3_schematic_details

Document Number: MXG REV:

Date: 02/06/2014 17:50:44 Sheet: 19/26

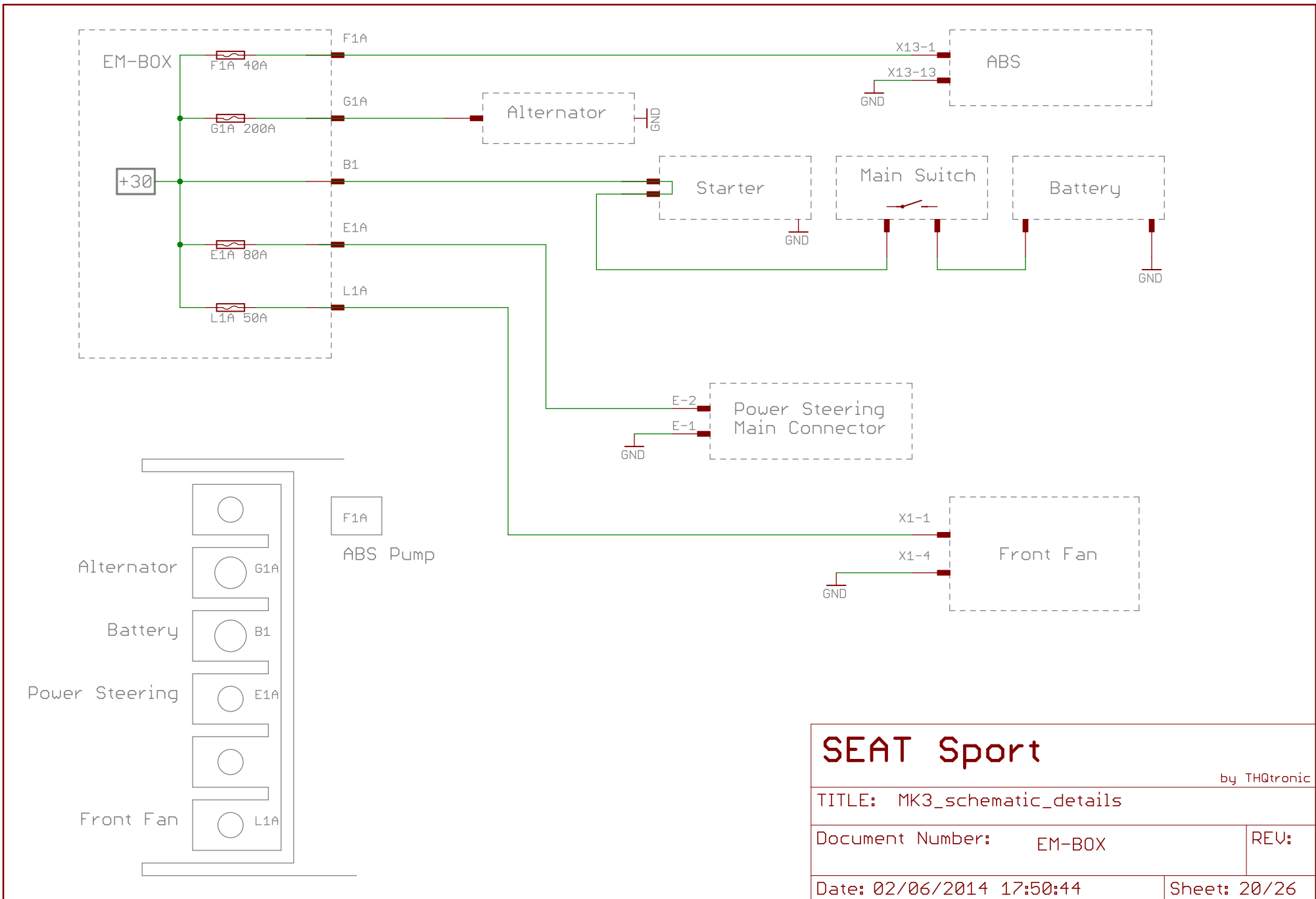

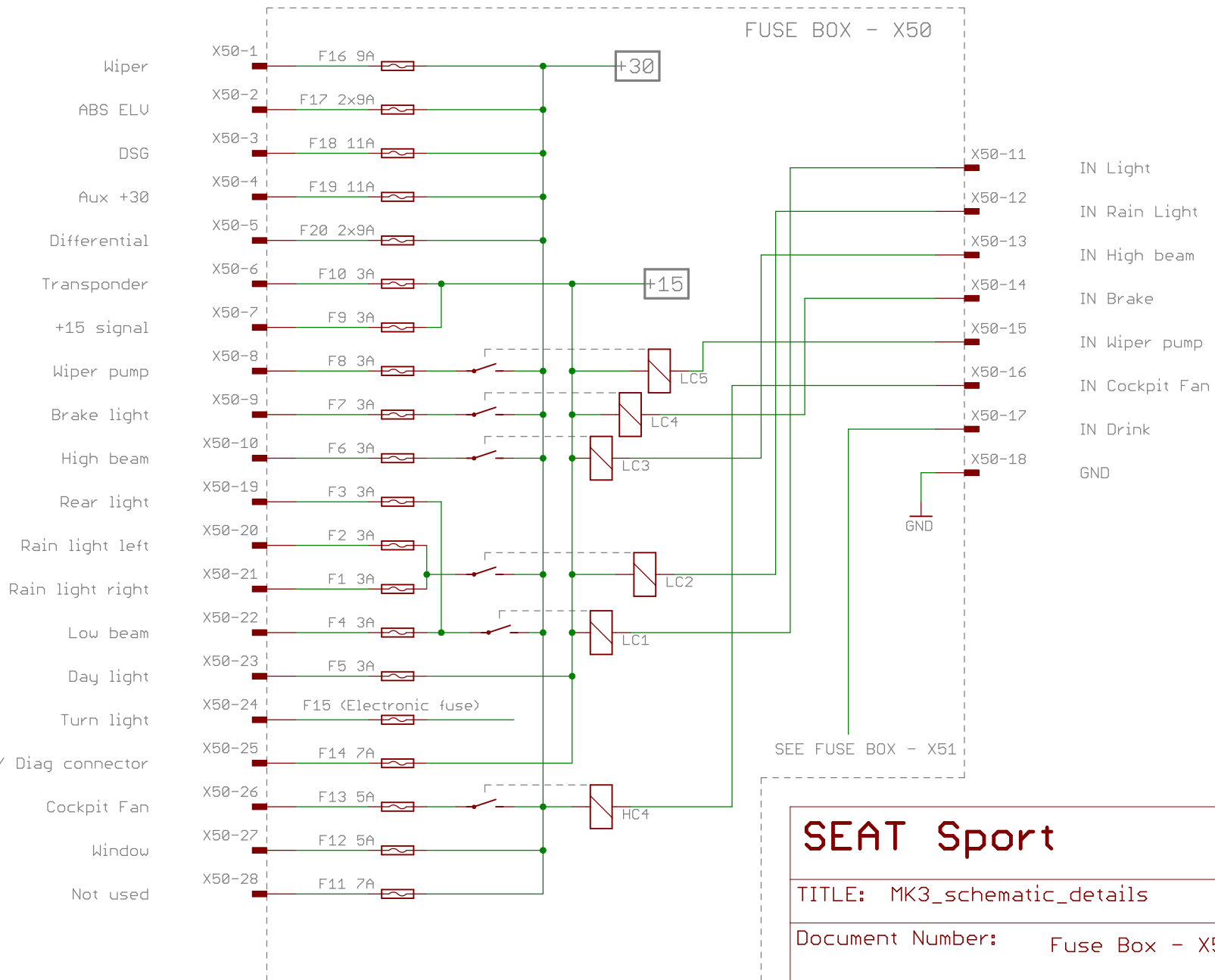

SEAT Sport		by THQtronic
TITLE: MK3_schematic_details		
Document Number:	Fuse Box - X50	REV:
Date: 02/06/2014 17:50:44	Sheet: 21/26	

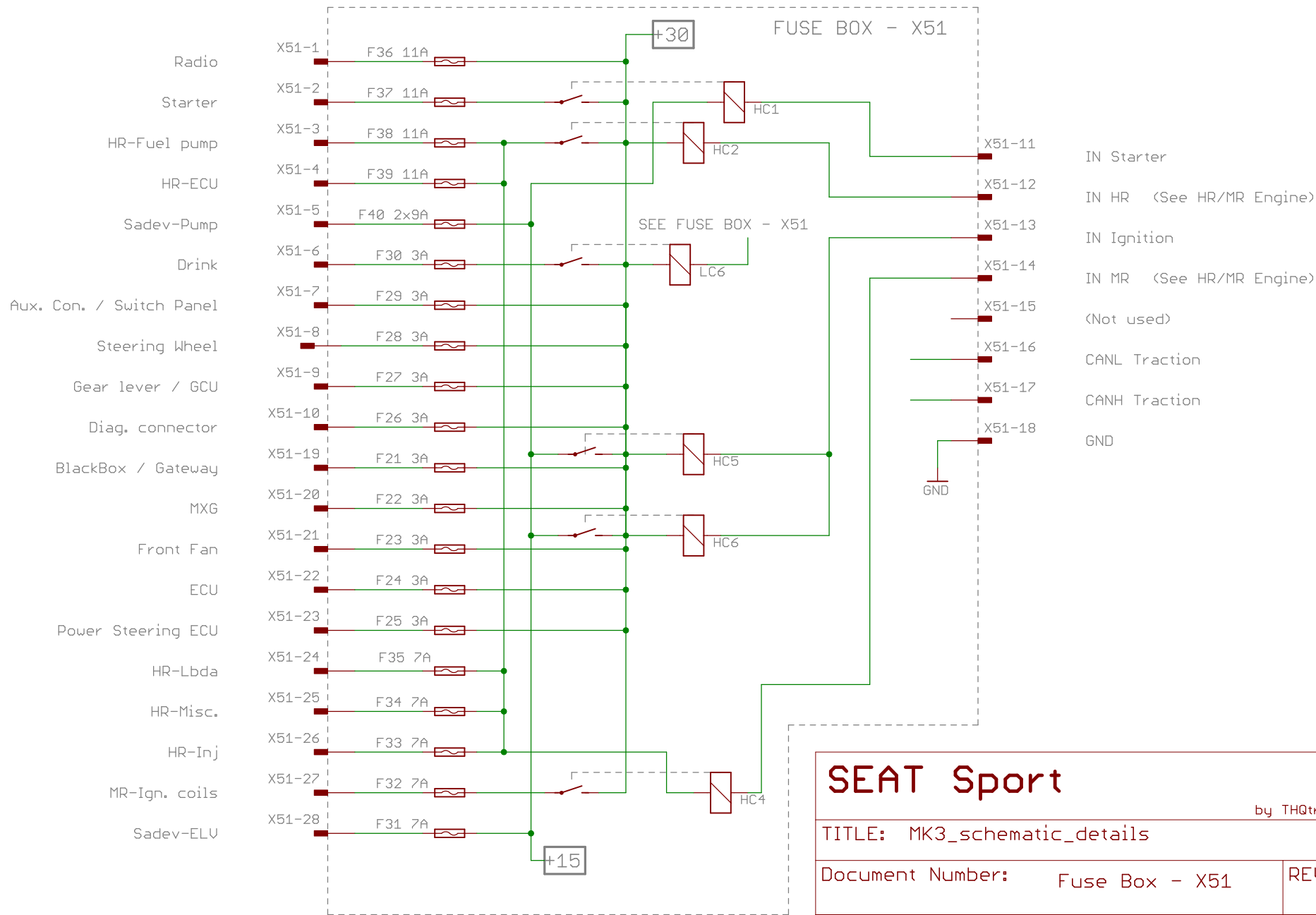

SEAT Sport		
by THQtronic		
TITLE: MK3_schematic_details		
Document Number:	Fuse Box - X51	REV:
Date: 02/06/2014 17:50:44	Sheet: 22/26	

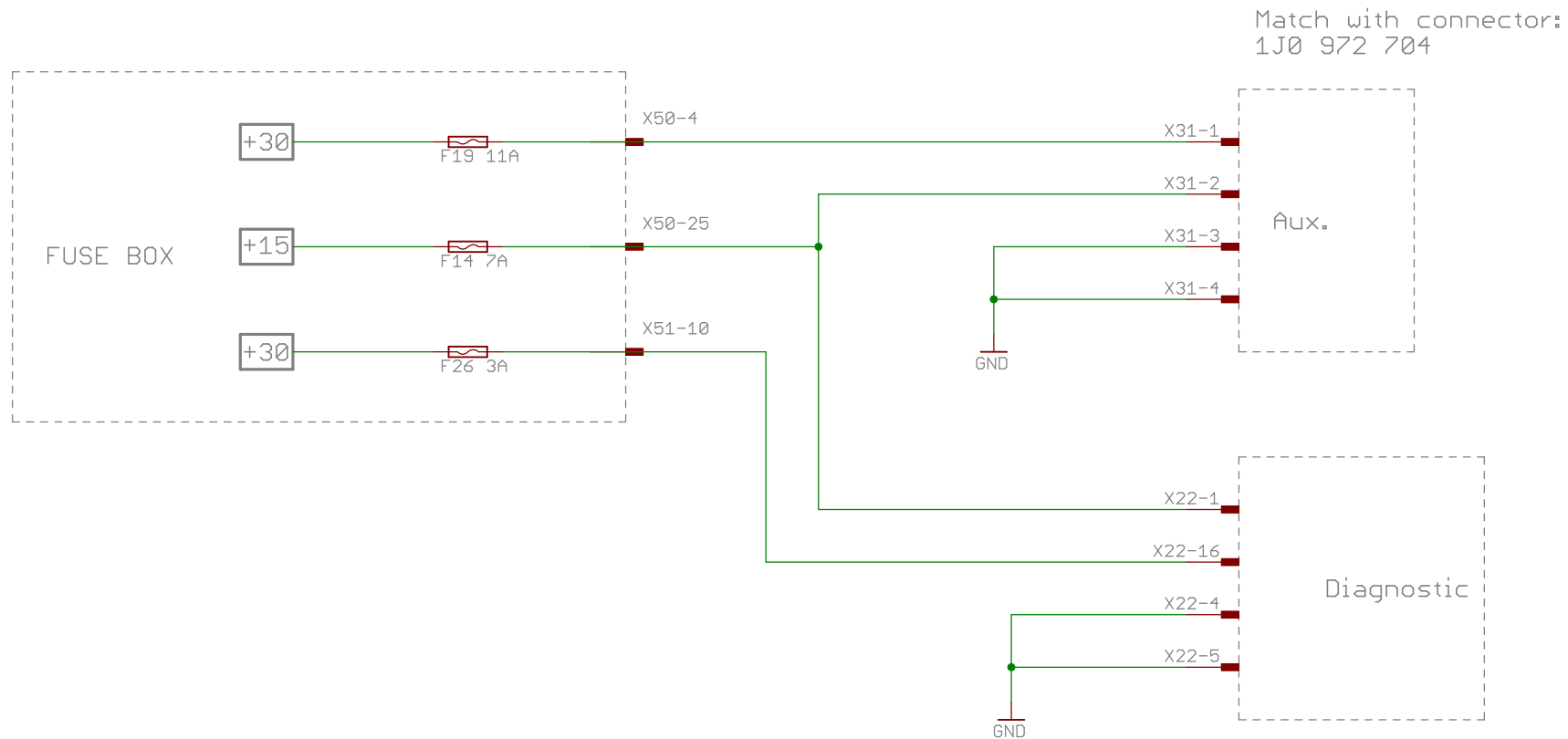

SEAT Sport

by THQtronic

TITLE: MK3_schematic_details

Document Number: Auxiliar / Diagnostic

REV:

Date: 02/06/2014 17:50:44

Sheet: 23/26

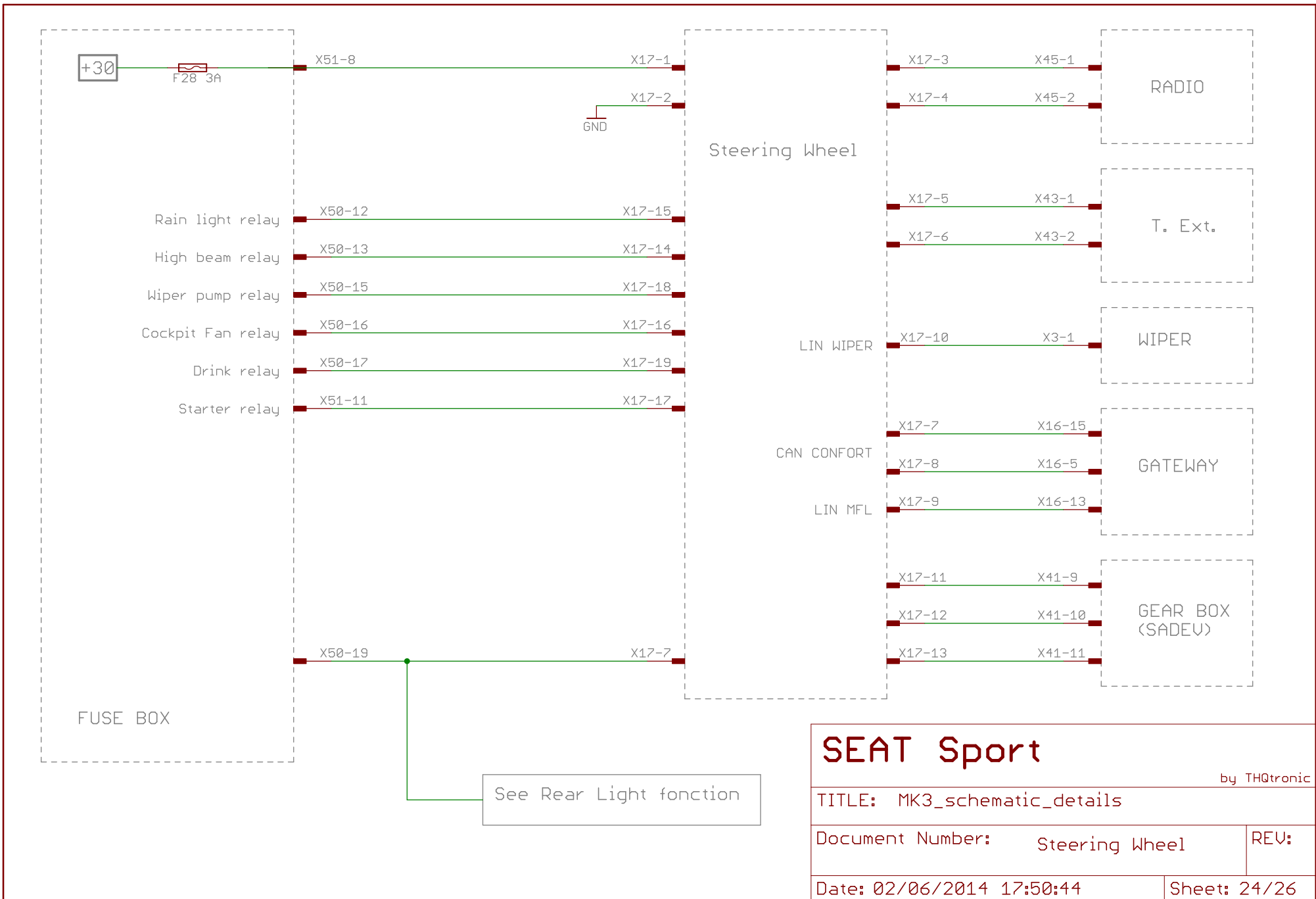

SEAT Sport

by THQtronic

TITLE: MK3_schematic_details

Document Number: Steering Wheel

REV:

Date: 02/06/2014 17:50:44

Sheet: 24/26

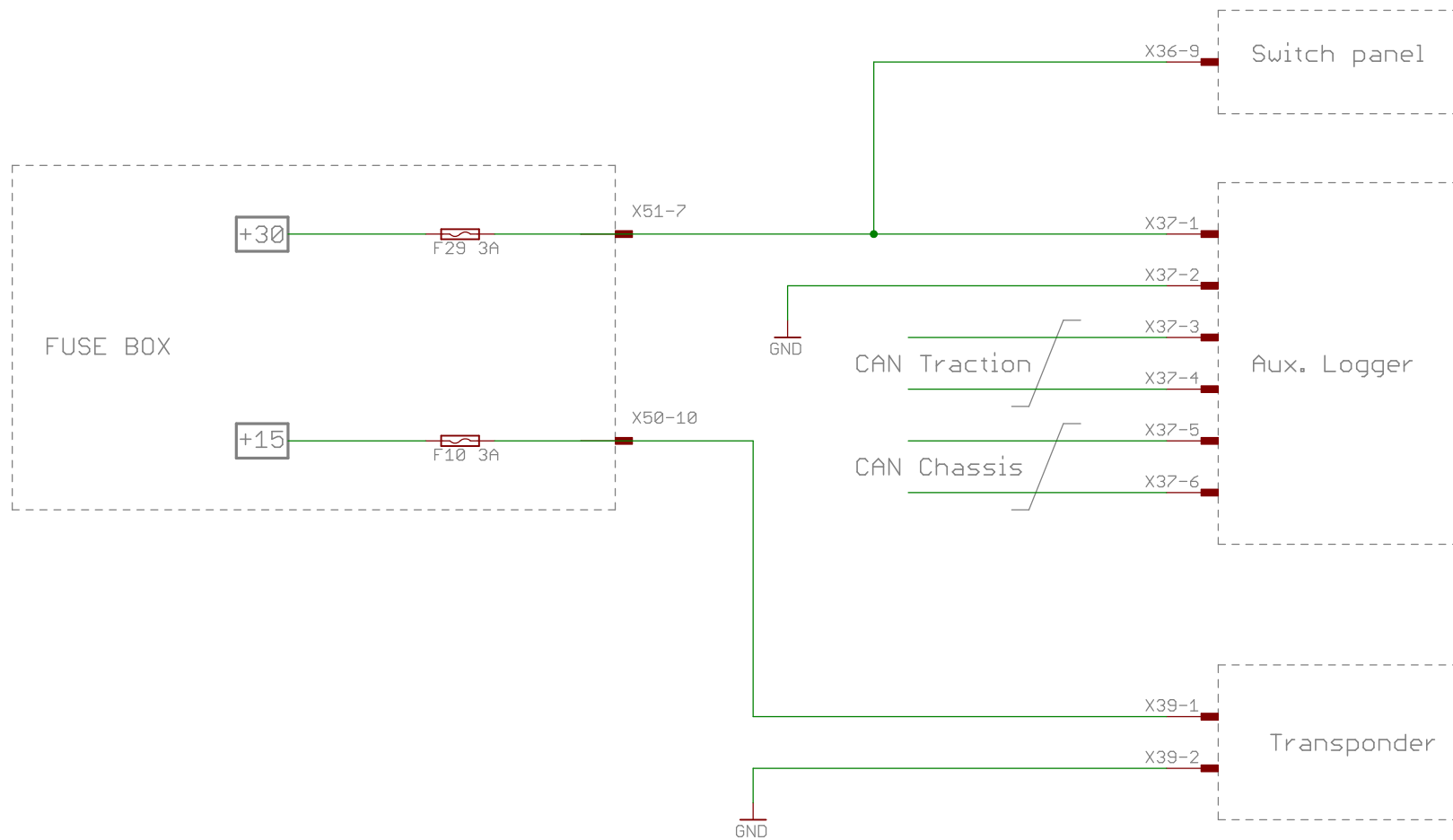

SEAT Sport

by THQtronic

TITLE: MK3_schematic_details

Document Number:
Aux. Logger / Transponder

REV:

Date: 02/06/2014 17:50:44

Sheet: 25/26

X1	Front Fan	1K0 906 234	X33	Fuel pump	1K0 973 752
X2	Wiper pump	1J0 973 722	X34	External main switch	Faston 6.35
X3	Wiper	8K0 973 724	X35	Black box	8E0 972 416
X4	Starter	1K0 973 751	X36	Switch panel	1-794617-2
X5	Alternator	4H0 973 714	X37	Aux. data logger	1J0 972 723
X6	Lambda	8K0 973 705 G	X38	MXG coupling	1-794615-6
X7	EM-Box		X39	Transponder	357 972 752
X8	Power steering coupling	4H0 973 713	X40	AIN8	1J0 972 703
X9	Differential unit	8D0 973 734	X41	Sadev coupling	3C0 973 737
X10	Fuel pump module	6N0 973 755	X42	Main switch coil	1J0 972 711
X11	Fuel level	4H0 973 713 G	X43	Ext. temperature sensor	8K0 973 702
X12	DSG	1J0 927 320	X44	P. Oil	4D0 971 993 A
X13	ABS	3C0 973 038 A	X45	Radio	4D0 972 704
X14	Engine coupling	5Q0 973 737	X46	P. Fuel	4D0 971 993 A
X15	DSG gear lever	1k0 972 776	X47	Cockpit fan	1J0 972 752
X16	Gateway	8E0 972 420	X48	Temp. sensor	8K0 973 702
X17	Steering wheel	2-794615-4	X50	Fusebox 1	064318-1011
X18	FL wheelspeed sensor	1J0 972 702	X51	Fusebox 2	064318-3019
X19	FR wheelspeed sensor	1J0 972 702	X52	IgnCoil out	1J0 972 702
X20	RL wheelspeed sensor	1J0 972 702	X53	IgnCoil in	1J0 972 712
X21	RR wheelspeed sensor	1J0 972 702	X54	Fuel pump out	1J0 972 752
X22	Diagnostic	3A0 972 695 A	X55	Fuel pump in	1J0 972 762
X23	Foot throttle	8K0 973 706			
X24	Front Right light	3C0 973 737			
X25	Front Left light	3C0 973 737			
X26	Rear right light	4B0 973 732			
X27	Rear left light	4B0 973 732			
X28	Rear gate	1J0 972 704			
X29	Drink	1J0 973 722			
X30	Left door	8K0 972 701			
X31	Auxiliar	4D0 972 704			
X32	ECU	7P6 906 971 A			

SEAT Sport

by THQtronic

TITLE: MK3_schematic_details

Document Number: Connector list

REV:

Date: 02/06/2014 17:50:44

Sheet: 26/26