

Dear customers.

### Fuel tank connectors cover

The fuel connections on the cockpit bay **must be protected** in all cars with FT3 fuel tank. This safety feature has been already introduced on the spare parts catalogue as well as on the SEAT Leon Cup Racer technical forms.

All necessary parts to adapt the existing cars with FT3 fuel tank are included on the kit reference: **5F6201027**

Reference	Description	Units per car	Prices
<b>5F6201027</b>	Fuel tank connectors cover	1	175,00€

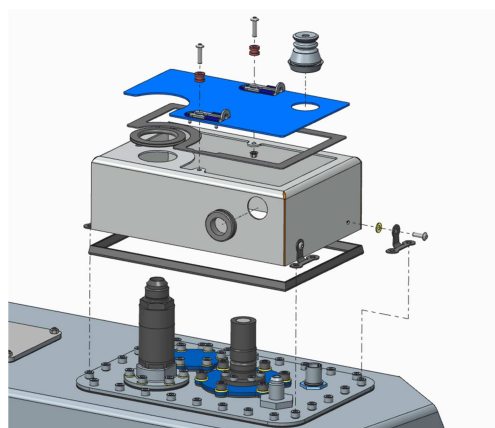
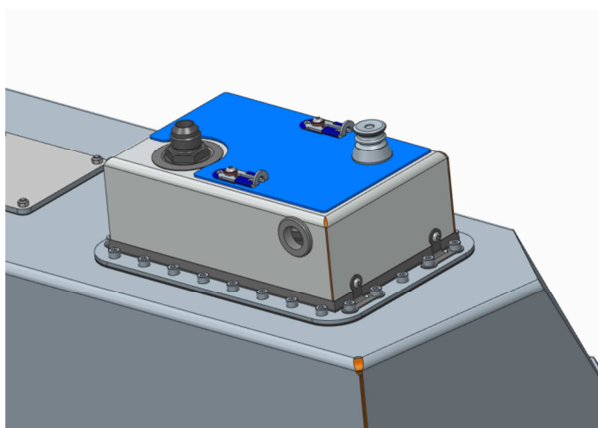

### Fuel line protection

The fuel line from the fuel tank to the engine bay has to be covered with a fire coating protection. You have two options to update it:

By adding a coating protection over the existing D6 pipe:

**or**

By replacing the D6 pipe for a new one already coated

Reference	Description	Units per car	Prices
<b>5F6201729</b>	Fire protection coating	1	70,40€
<b>5F6201757</b>	Fuel hose(with coating)	1	310,00€

# SEAT LEON CUP RACER 2016

## TECHNICAL NOTE 10/2016

### Fast refueling kit

SEAT Sport has developed an optional “fast refueling kit” (refueling by gun) for endurance races use.

All necessary parts to adapt the SEAT Leon Cup Racer cars with FT3 fuel tank standard refueling to “fast refueling” system, are included on the kit reference: **5F6198007**

Reference	Description	Units per car	Prices
<b>5F6198007</b>	External refuelling kit	1	1.350,00€

